

ROBIT® GEOTECHNICAL PRODUCT CATALOGUE

The Experts in Geotechnical Drilling Tools

- Casing Advancing Systems
- DTH Bits
- DTH Hammers
- Shock Absorbers
- Drill Pipes
- Accessories



Robit
FURTHER. FASTER.



ROBIT® GEOTECHNICAL PRODUCT CATALOGUE

Copyright © 2026, Robit Plc

All rights reserved. No part of this catalogue may be reproduced or transmitted in any form or by any means, electronic or mechanical, including photocopying, recording, or by any information storage and retrieval system, without written permission from the publisher.

Trademarks

Robit is a trademark of Robit Plc

Publisher

Robit Plc

www.robitchgroup.com

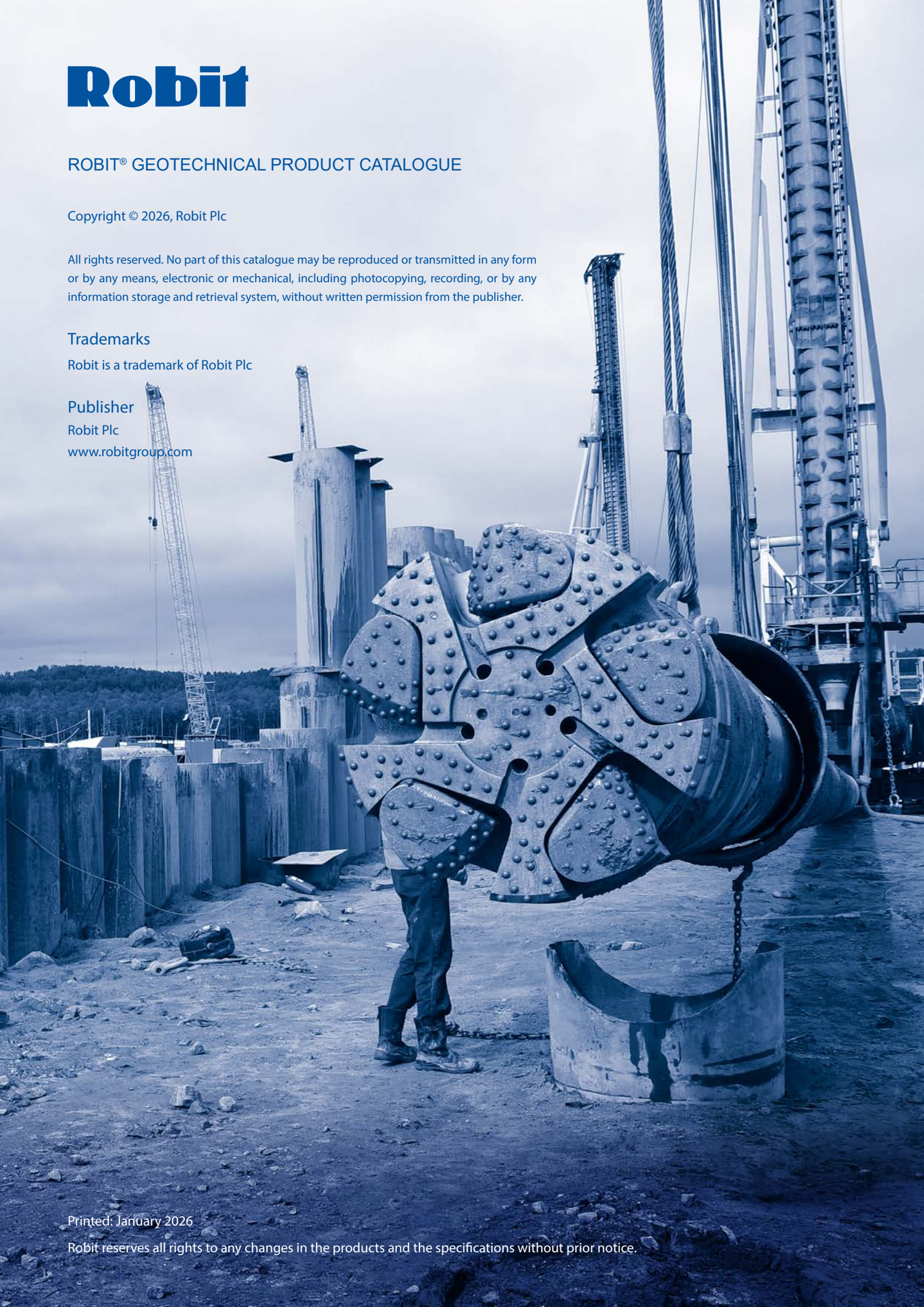

Printed: January 2026

Robit reserves all rights to any changes in the products and the specifications without prior notice.

CONTENTS



CONTENTS.....	3	DTH BITS	43
ROBIT IN BRIEF	4	BIT SELECTION GUIDE	44
PRODUCT LINES.....	6	STANDARD BIT SIZES.....	47
GEOTECHNICAL APPLICATIONS	7	DTH HAMMERS.....	49
ROBIT GEOTECHNICAL OFFERING	10	H SERIES HAMMER CODES	50
CASING ADVANCING SYSTEMS	13	BR, H & HYPER SERIES HAMMERS.....	53
CASING SYSTEMS CODES.....	14	BR2	54
AUTOMATIC SPIRAL LOCKING	14	HYPER 31	55
CASING INSTALLATION.....	14	H4	56
CASING SYSTEMS CODES.....	15	H5	57
ROBIT FLOW CONTROL SYSTEM.....	15	H6	58
SYSTEM PARTS AND DIMENSIONS.....	16	H8	59
STANDARD SHANK DESIGNS.....	17	HYPER 101	60
DRILLING WITH CASING SYSTEMS.....	17	HYPER 121	61
SHANK GUIDE	18	HYPER 141	62
EXAMPLE DRILLING PARAMETRES	21	H18	63
CASING SYSTEMS FOR PILING.....	22	HYPER 241	64
DTH Prime	26	HYPER 241 TL	65
DTH Prime DT	26	HYPER 331	66
DTH SR	28	SHOCK ABSORBERS.....	69
DTH SF (STEEL FIST).....	30	2"- 6" Shock Absorbers.....	70
CASING SYSTEMS FOR WELL DRILLING	32	8"-10" Shock Absorbers.....	71
DTH Nova	34	12" - 14" Shock Absorbers.....	72
DTH-REC.....	36	18" Shock Absorber	73
MULTI-PURPOSE CASING SYSTEMS	38	24" - 33" Shock Absorbers.....	74
DTH-RoX MU	40	DRILL PIPES	77
		Drill Pipes - Single Pipe	78
		Drill Pipes - Double Pipe.....	80
		ACCESSORIES.....	83
		Accessories.....	84
		Air hoses & chain keys.....	85
		Hammer oil	85



ROBIT IN BRIEF

The Experts in Drilling Tools

Robit is a global expert focusing on high-quality drilling tools for mining and construction markets to help you drill further and faster. Robit strives to be world number one company in drilling tools.

Through our high and proven quality Top Hammer, Down the Hole and Geotechnical products, combined with our expert services, we deliver concrete savings in drilling costs to our customers.

Robit has its own sales and service points in seven countries and an active distributor network with a global footprint selling to more than 100 countries. Robit's manufacturing units are located in Finland, South Korea, and the United Kingdom.

Robit is listed in Nasdaq Helsinki Ltd's marketplace with trading code ROBIT.

For more information, visit robitgroup.com





Geotechnical Business

Robit's Geotechnical business line focuses on geotechnical applications, particularly anchoring, micropiling and underpinning, piling, and well drilling. Geotechnical applications are most commonly related to drilling done before or as a part of a construction process. Our selection contains a wide variety of specialized hammers, drill bits and ring bits, as well as advanced casing systems for all your needs.

Down the Hole Business

The Down the Hole business line covers all operations related to the down the hole drilling method. The main product categories consist of DTH hammers, DTH bits and DTH tubes. The selection is competitive and encompasses top quality products for all your drill & blast as well as well-drilling applications.

Top Hammer Business

Robit Top Hammer business line covers all applications in construction, quarrying and mining, as well as blasting and forepoling, from the softest to the hardest of rock conditions. Underground construction is one of the most important customer segments for Robit bits, and applications such as drifting and bolt hole drilling are well catered for, as well as RoX top hammer casing systems for tunneling support. Robit's quality has been approved worldwide by major mining and quarrying customers. The selection is wide and encompasses products, such as: drifting and tunneling bits, reaming equipment, bench and production drilling bits, rods, shanks, couplings, and auxiliary tools, such as button bit adapters.

We offer You:

- *The highest quality in drilling tools – our focus is 110% in drilling tools*
- *Proven excellence in drilling performance – backed by numerous references*
- *We emphasize short lead time and precise deliveries from our 3 factories, supported by comprehensive local availability on every continent.*

Robit is following together with its key customers the development steps of more powerful hydraulic drifters. Robit is modelling and simulating the dynamic forces and stresses, and innovates new solutions to meet the drillers' needs for the best performance, efficiency and lifetime.

More info about Robit's products and digital catalogues at company's website: www.robitegroup.com.

MICROPILING, PILING, AND UNDERPINNING

Micropiling and underpinning are terms relevant to construction. They all have to do with building, stabilizing, and/or strengthening foundations, with underpinning being more of an umbrella term for different methods, while micropiling and piling describe some of those methods.

During decades and centuries of continuous urbanization, the best, most solid and thus suitable ground for construction has often been already populated or utilized for some other purpose. The remaining softer ground conditions require a stabilizing technique before construction, which is where underpinning comes into play. There are several other techniques under the umbrella of underpinning, however, micropiling and piling are the ones most centered on drilling. They are also the most versatile of the lot, and some of the more reliable ones.

Micropiling and piling involve drilling high-durability steel casings into considerable depths. They are usually driven through the overburden until the design depth, where they reach the solid bedrock. Once the desired depth has been reached, the drill with the drill bit is removed, leaving the steel casing into the ground. After this, a reinforcing bar is inserted into the casing, extending all the way to the surface, and the casing is filled with high-strength cement grout that surrounds the reinforcing bar.

Drilled piles made with Robit® Casing Systems have significant advantages compared to other piling methods and systems. These benefits include fast drilling with maximum straightness of the hole, reliability to reach the targeted depth, and extreme simplicity of use.



WELL DRILLING

Well drilling, which is often also referred to as casing drilling, is used in making water and thermal wells in broken overburden conditions. The process is principally the same as when looking to extract other natural resources, such as oil or natural gas, from the ground. It involves drilling a hole into the ground using a rig outfitted most commonly with a top hammer (TH) or a down the hole hammer (DTH), although sometimes also rotary drills may be used.

For water well drilling, the drill bit is driven through the soil until the ground water table, and then below that to make sure that the well has enough water to work with and will continue to provide water for a long time. When drilling a geothermal well, the end of the pipe is driven deep into the bedrock to extract the heat from it. The bit is followed by a steel casing that will stay in the hole, ensuring its straightness and supporting its walls. In softer rock, the casing is a vital part of the construction, as it prevents the collapse of the hole during drilling and protects the water below from contamination or the blockage of the heat distribution. In hard enough rock, such as the one mostly found in Scandinavia, the casing is drilled only 2-3 meters into bedrock, after which no extra support is needed, and the drilling continues with a standard DTH drill bit. Once the drilling is done, either a water pump or a heat pump system is installed.

Robit® Casing Systems allow easy driving of the casing tubes into the ground with relatively low torque demand. The casing is left in the ground as a protection pipe of the water or thermal well. The WH Series Hammers offer excellent performance in a variety of rock conditions.



ANCHORING

Anchoring is a method used in construction, where walls with masses of overburden are anchored to the solid rock using steel casings filled with grouting. This can be used to anchor great masses to the bedrock. Anchoring increases the stability and durability of the construction by transferring both tension and shear forces. These structures are also known as ground anchors or earth anchors, and they come in different forms and sizes that can be used to support buildings or civil engineering and other structures.

To start, casing tubes are driven through the already laid overburden, using special casing systems. Once the casings are in place through the wall, the drilling can proceed with a ground or rock drill bit. After this, the drill will be driven deep enough into the bedrock or the ground beyond the overburden walls; the depth is usually defined by the weight the anchor is supposed to support and the quality of the ground or rock. Finally, to finish the anchoring, a steel cable is inserted to the bottom of the hole and the hole is filled with grouting.

Ground anchors have a wide variety of benefits, which plays into their multiple use cases. They are lightweight and resist corrosion, which makes them suitable for different types of soil. They are easy and quick to install, creating only minimal disturbance on the soil. Earth anchors also have a low environmental impact, while simultaneously being able to achieve a holding capacity of up to 3 000 kN.



Competitive offering in Geotechnical drilling tools



Patented Casing Advancing Systems with spiral locking. Sizes from 114,3 mm up to 1524 mm. Wide range of ring bit, wing bit, eccentric and drill through models. Proven quality worldwide – references in all applications.



Efficient DTH Bits – For drilling blast holes, wells; for general purposes as well as RC models for sampling. Robust designs for achieving maximum penetration rate in hard and abrasive rock conditions.



Robust DTH Hammers – Wide range of all sizes of blast hole, general purpose, well drilling, and reverse circulation hammers. Hammers have robust design as well as minimized fuel consumption and optimized air flow with the highest performance.



Reliable Shock Absorbers – Efficient dampening available for hammers from 2" up to 33".



Strong Drill Pipes – Single pipes available from OD 76 mm up to 323 mm sizes and double pipes from OD 406 mm up to 1220 mm. Tool joints API reg. and HEX standards.



Wide range of Accessories – Wide range of subs, check valves, hammer sleeves, air hoses, and chain keys. Ask for more: sales@robitgroup.com

Proven quality – manufactured with automated production lines

- Robust design for abrasive ground conditions
- High penetration rate in hard rock
- Patented spiral locking system for casing systems
- Drill through technology in piling



Reliable partner

Competitive offering in drilling consumables – Proven quality – Customization for project needs – Drill master service – Solving drilling challenges and problems
– Experience – References



Robit



CASING ADVANCING SYSTEMS

DTH Prime

DTH Prime DT

DTH SR

DTH SF

DTH Nova

DTH-REC

DTH-RoX MU



CASING SYSTEMS CODES

Automatic spiral locking

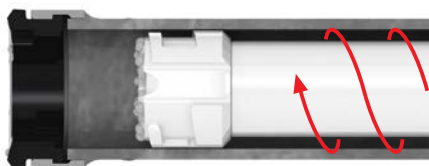

1.) Drive the pilot bit through the casing tube

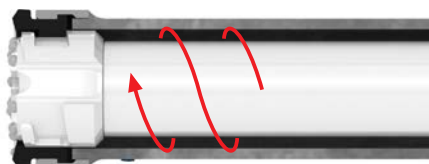

2.) Rotate to locked position in the ring bit

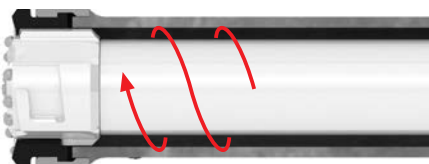

3.) Robit® Casing System is READY TO DRILL

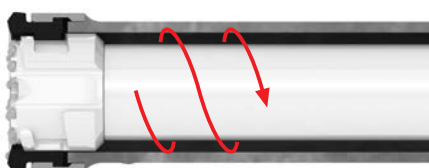

4.) Finish drilling by rotating the pilot bit in opposite direction and pulling it out

Casing installation

Model

Permanent Casing

Temporary Casing

DTH Prime



x

DTH Prime DT



x

DTH SR



x

x

DTH SF



x

x

DTH Nova



x

x

DTH-REC



x

x

DTH-RoX MU



x

x

Casing Systems codes

Example: DTH-RoX MU 114.3-10

DTH	RoX	MU	114.3	10
Type of use	Product group	Model	Casing outer diameter	Maximum casing wall thickness
DTH (Down the Hole)	RoX (Spiral locking)	MU (Multi-Use)	114,3 mm (4 1/2")	10 mm (0.394)
	Prime	DT (Drill Through)	1524 mm (60")	5 mm (0.197)
	SR (Solitary Ring)	FC (Flow Control)		25,4 mm (1.000)
	SF (Steel Fist)	DF (Direct Flush)		
	REC			

Robit Flow Control System

Background:

Experts have voiced growing concerns about compressed air escaping into certain ground conditions when drilling with DTH hammers in urban areas, close to existing structures.

- Overdrilling in *soft, sandy formations* often removes more material than anticipated, changing the ground's characteristics
- In *clay formations*, air may travel long distances and disturb the soil

Conventional Flushing



Flow Control



Method:

Robit has developed the Flow Control system, which ensures efficient flushing without compressed air escaping into the surrounding ground.

- The main air flow is directed from the pilot bit straight to the outlet channels inside the casing so that a vacuum effect is created
- The ring bit runs ahead of the pilot, which also prevents the air from escaping into the surrounding ground
- The inclined air channels in front of the pilot take care of sweeping drill cuttings to flushing outlets and enable effective drilling
- Advanced Computational Fluid Dynamics (CFD) analysis has been used to optimize and verify the flushing properties of Robit® Flow Control technology
- Distributed air jet concept, with smaller channels in the pilot face, provides superior flow control with varying operating pressures
- Air flow always finds a path of least resistance that can be observed from the analysis of comparison design

Direct Flushing

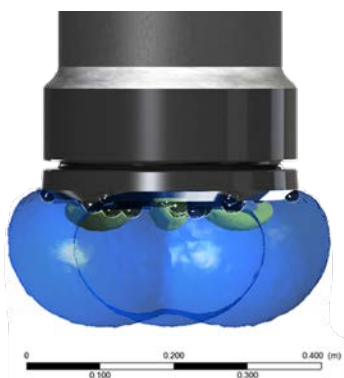

Robit® Flow Control



Result:

Robit® Flow Control system is optimized for effective drilling and preventing air from escaping into the ground.

- Conventional flushing causes three times bigger cavern size, where the flowing air disturbs the ground, in comparison to the Robit Flow Control model
- Competing models have approximately 20% bigger cavern size, in comparison to the Robit Flow Control model

System parts and dimensions

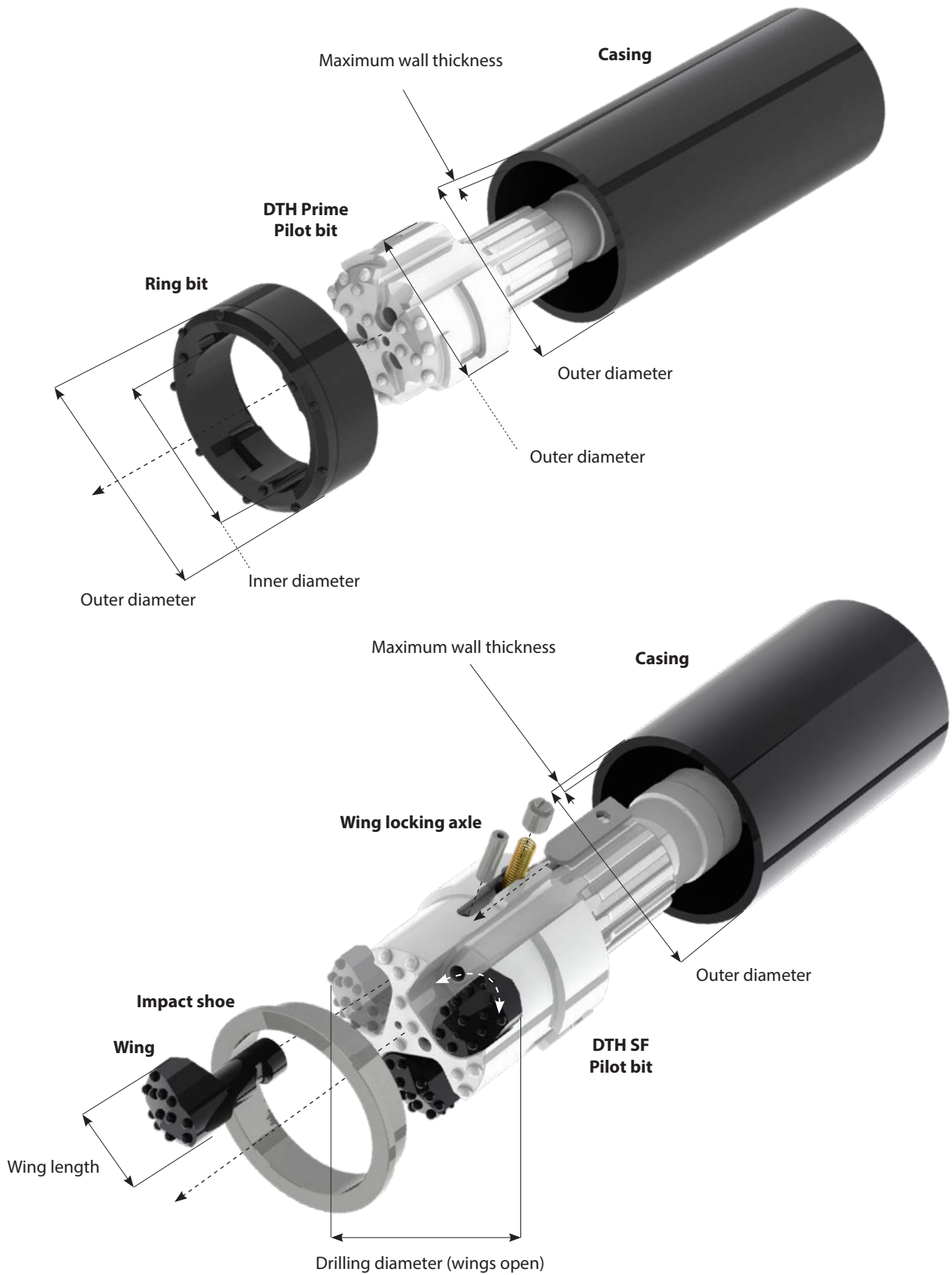

Standard shank designs

Robit® system size

[mm]	[in]	
114,3	4 ½	DHD 3,5"
127,0	5	DHD 3,5", DHD 340, TD 40
133,0	5 15/64	DHD 340, TD 40
139,7	5 ½	DHD 340, TD 40
152,4	6	DHD 340, TD 40
168,3	6 5/8	DHD 350, QL 50
177,8	7	DHD 350, QL 50
193,7	7 5/8	DHD 360, QL 60
219,1	8 5/8	DHD 360, QL 60
244,5	9 5/8	DHD 360/380, QL 60/80
254,0	10	DHD 380, QL 80
267,0	10 ½	DHD 380, QL 80
273,0	10 3/4	DHD 380, QL 80
301,6	11 7/8	DHD 380, QL 80
323,9	12 3/4	DHD 380, QL 80, SD-10
339,0	13 11/32	DHD 380, QL 80, SD-10/12
355,6	14	DHD 112, QL 120, SD-10/12, N125
377,0	14 27/32	DHD 112, QL 120, SD-10/12, N125

Standard shank design

[mm]	[in]	
406,4	16	DHD 112, QL 120, SD-10/12, N125
426,0	16 49/64	DHD 112, QL 120, SD-12, N125
457,2	18	DHD 112, QL 120, SD-12, N125
508,0	20	DHD 112, QL 120, N125/180
558,8	22	N180
609,6	24	N180
660,4	26	N180/240
711,2	28	N180/240
762,0	30	N180/240
812,8	32	N180/240
914,4	36	N180/240/330
1016,0	40	N240/330, H331
1220,0	48	N240/330, H331
1300,0	51 3/16	H331
1320,0	52	H331
1420,0	55 29/32	H331
1500,0	59 1/16	H331

For all inquiries on other shank designs, please contact Robit sales.

Drilling with casing systems

1. Pulldown/Feed force

The moderate pulldown force on pilot is 9 kg/ring bit OD in mm (500 lbs/inch)

2. Rotation speed

Normal operating RPM is 7620/ring bit OD in mm (see chart 1.)

3. Compressor pressure

Normal operating pressure is from 12 to 15 bar or 180 to 225 psi. Note: in loose formation (i.e. sand) compressor can be set to 7 bar or 100 psi

4. Flushing

Drill exhaust air passes through the bit to clean the bit face and carry cuttings to the surface up the annular space between the drill pipe and the casing tube. Air velocity varies from 12 to 18 m/s between drill rod and casing.

Drill rod and casing gap is typically ~50 mm under Ø406 mm systems. With the bigger diameters the gap will grow.

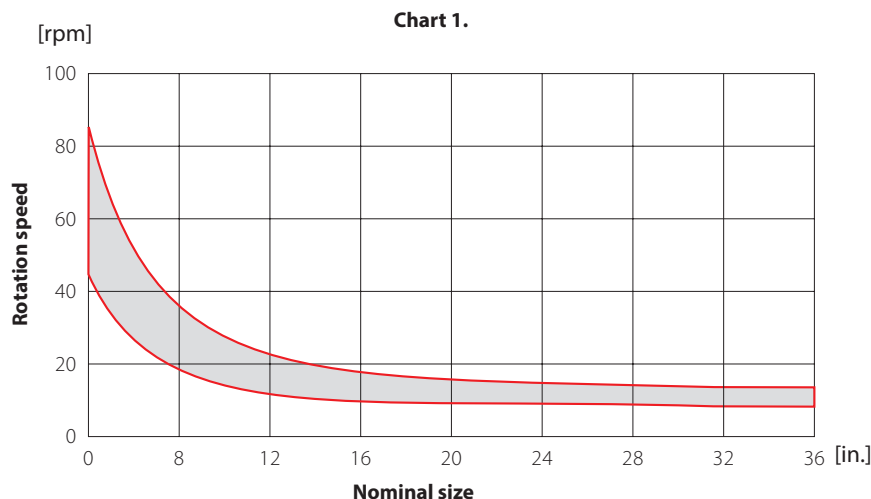



SHANK GUIDE



Model	TD 40 COP 44 G QLX 40	DHD 340 COP 44 DHD 4 QL 340	QL 50 TD 50 COP 54 G	DHD 350 COP 54 DHD 5
Splines	12	8	12	8
Drive plates/pins	No	No	No	No
Shank length (mm/in)	209 / 8 15/64	210 / 8 17/64	240 / 9 29/64	261 / 10 9/32
Shank upper Ø (mm/in)	68 / 2 43/64	64 / 2 33/64	76 / 2 63/64	81 / 3 3/16
Shank lower Ø (mm/in)	69 / 2 23/32	65 / 2 9/16	88 / 3 15/32	84 / 3 5/16
Valve Ø (mm/in)	32 / 1 17/64	27 / 1 1/16	38 / 1 1/2	35 / 1 3/8



Model	QL 60 TD 60/65/70 COP 64 G	DHD 360 COP 64 DHD 6	QL 80	DHD 380 COP 84 DHD 8
Splines	12	8	16	10
Drive plates/pins	No	No	No	No
Shank length (mm/in)	254 / 10	306 / 12 3/64	332 / 13 5/64	350 / 13 25/32
Shank upper Ø (mm/in)	92 / 3 5/8	87 / 3 27/64	118 / 4 41/64	127 / 5
Shank lower Ø (mm/in)	106 / 4 11/64	101 / 3 31/32	136 / 5 23/64	129 / 5 5/64
Valve Ø (mm/in)	46 / 1 13/16	38 / 1 1/2	54 / 2 1/8	51 / 2 1/64



Model	QL 100	N 100	SD-10
Splines	12	10	8
Drive plates/pins	Yes	No	No
Shank length (mm/in)	410 / 16 ⁹ / ₁₆	375 / 14 ⁴⁹ / ₆₄	355 / 13 ³¹ / ₃₂
Shank upper Ø (mm/in)	150 / 5 ²⁹ / ₃₂	164 / 6 ²⁹ / ₆₄	139 / 5 ¹⁵ / ₃₂
Shank lower Ø (mm/in)	168 / 6 ³⁹ / ₆₄	165 / 6 ¹ / ₂	165 / 6 ¹ / ₂
Valve Ø (mm/in)	58 / 2 ⁷ / ₃₂	55 / 2 ¹¹ / ₆₄	56 / 2 ¹³ / ₆₄



Model	QL 120	N 125	IR 112	SD-12
Splines	12	10	8	8
Drive plates/pins	Yes	Yes	Yes	No
Shank length (mm/in)	489 / 19 ¹ / ₄	490 / 19 ¹⁹ / ₆₄	490 / 19 ¹⁹ / ₆₄	470 / 18 ¹ / ₂
Shank upper Ø (mm/in)	187 / 7 ²³ / ₆₄	192 / 7 ⁹ / ₁₆	154 / 6 ⁷ / ₁₆	158 / 6 ⁷ / ₃₂
Shank lower Ø (mm/in)	209 / 8 ¹⁵ / ₆₄	209 / 8 ¹⁵ / ₆₄	183 / 7 ¹³ / ₆₄	185 / 7 ⁹ / ₃₂
Valve Ø (mm/in)	73 / 2 ⁷ / ₈	76 / 2 ⁶³ / ₆₄	63 / 2 ³¹ / ₆₄	63 / 2 ³¹ / ₆₄



Model	N 180	N 240
Splines	12	12
Drive plates/pins	Yes	Yes
Shank length (mm/in)	530 / 20 ⁵⁵ / ₆₄	564 / 22 ¹³ / ₆₄
Shank upper Ø (mm/in)	273 / 10 ³ / ₄	343 / 13 ¹ / ₂
Shank lower Ø (mm/in)	296 / 11 ²¹ / ₃₂	367 / 14 ²⁹ / ₆₄
Valve Ø (mm/in)	93 / 3 ²¹ / ₃₂	113 / 4 ²⁹ / ₆₄



Model	H331
Splines	12
Drive plates/pins	Yes
Shank length (mm/in)	600 / 23 ⁵ / ₈
Shank upper Ø (mm/in)	557 / 21 ⁵⁹ / ₆₄
Shank lower Ø (mm/in)	559 / 22 ¹ / ₆₄
Valve Ø (mm/in)	No valve

EXAMPLE DRILLING PARAMETERS

DTH Nova

Product	DTH Nova 168.3-6
Rock / Ground conditions	All rock and ground formations
Application	Well drilling
DTH hammer size	5"
Rotation speed	30 - 40 RPM
Torque	1500 - 2000 Nm
Compressor output	15 - 24 m ³ /min 530 - 848 CFM
Compressor pressure	10 - 16 bar

NOTE: Parameters may vary depending on ground / rock conditions, application, and machinery.

DTH SF

Product	DTH SF 323.9-12.7
Rock / Ground conditions	Homogenous soil with small boulders
Application	Piling and Pipe-Pile-Wall
DTH hammer size	8" - 10"
Rotation speed	15 - 25 RPM
Torque	7000 - 10000 Nm
Compressor output	24 - 33 m ³ /min 848 - 1165 CFM
Compressor pressure	10 - 14 bar

NOTE: Parameters may vary depending on ground / rock conditions, application, and machinery.

DTH Prime

Product	DTH Prime 609.6-19.0
Rock / Ground conditions	All rock and ground formations
Application	Piling
DTH hammer size	18"
Rotation speed	10 - 14 RPM
Torque	2200 - 2900 Nm
Compressor output	57 - 103 m ³ /min 2000 - 3670 CFM
Compressor pressure	11 - 15 bar

NOTE: Parameters may vary depending on ground / rock conditions, application, and machinery.

CASING SYSTEMS FOR PILING



Casing Systems for Piling

Top-quality casing systems for piling operations under various challenging conditions. Includes systems with drill-through capabilities, solitary ring bits for economical drilling, and a Steel Fist system, which requires no ring bit. Robit piling products are designed to work with a wide range of casing wall thickness (6-32 mm).

Suitable applications:

- Piling
- Micropiling
- Underpinning
- Pipe-Pile-Wall installation



Robit® DTH Prime

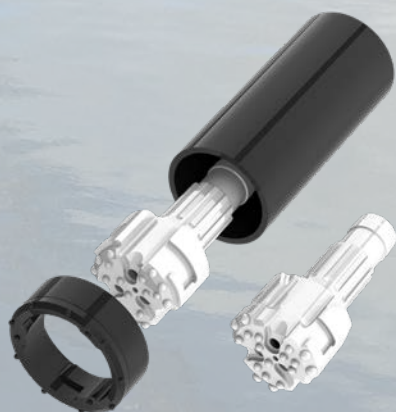

Robit® DTH SR



Robit® DTH SF (Steel Fist)



XL2 MODELS FOR INSTALLING PIPE-PILE WALLS

Case: Finland, Helsinki Länsi-Metro, Koivusaari Subway Station Pipe-Pile-Wall Piling Project with Robit® DTH SF XL2 609,6/16



The most reliable application for challenging conditions

Robit has a versatile tools for building steel foundation in the most demanding conditions. When it's matter of structures that require maximum horizontal or vertical load-bearing capacity, faster implementation of retaining walls or extremely wet soil conditions, Robit® Casing Systems for Pipe-Pile-Wall is the right solution. Drilling with Robit® Casing Systems down to the bedrock, steel pipes are connected one by one each others with pre-welded interlocks building up a waterproof wall. Pipe pile walls have also excellent bending stiffness and resistance. Robit® Casing Systems for Pipe-Pile Walls are suitable for using for example in the following applications: retaining wall structures, building foundations, wharves and piers, road and railway structures, bridges.

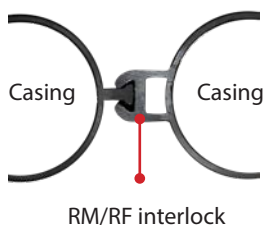

When using XL2 ring bits, drilling drives the space for pre-welded interlocks. With the same pilot bit, it's possible to pile both standard and XL2 ring bits.

XL2 MODELS FOR INSTALLING PIPE-PILE WALLS



Case: Estonia, Paldiski New Northern Port Combi Wall Piling Project with Robit® DTH SF 1020





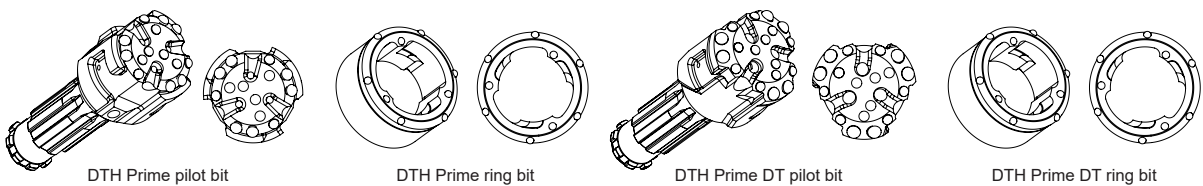

DTH Prime

Durable piling solutions for demanding conditions



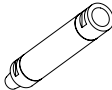

- Available for piling applications ranging from 114,3 (4 ½") to 1524 mm (60")
- Allows for the drilling of both threaded and welded casing tubes with the same ring bit
- Pile coupling structure makes fitting and welding easy
- Ring bit carry capacity guaranteed to exceed the burden of maximum casing grades (S550)
- Enhanced ring bit durability, thanks to large gauge buttons
- Optimized flushing grooves for the toughest of conditions
- Optional Flow Control model minimizes air escaping to the surrounding ground
- Reliable spiral locking mechanism
- Prime DT pilot allows for continuing drilling through the ring assembly
- The same ring assembly works with DTH Prime and DTH Prime DT pilot bit



DTH Prime & DTH Prime DT (Drill Through) Pilot Bit

Item size	Casing				Pilot bit				Hammer	Weight	
											
	[mm]	[in]	[mm]	[in]	[mm]	[in]	[mm]	[in]			
114.3-10	114,3	4 ½	10,0	0.394	91,5	3.602	90,6	3.567	3"	6	13
139.7-10	139,7	5 ½	10,0	0.394	116,0	4.567	114,0	4.488	4"	10	22
152.4-12.7	152,4	6	12,7	0.500	126,0	4.882	124,0	4.882	4"	11	24
168.3-12.7	168,3	6 ⅝	12,7	0.500	140,0	5.512	138,0	5.433	5"	18	40
177.8-14	177,8	7	14,0	0.551	146,0	5.748	146,0	5.748	5"	19	42
193.7-12.7	193,7	7 ⅝	12,7	0.500	166,0	6.457	164,0	6.457	6"	29	64
219.1-12.7	219,1	8 ⅝	12,7	0.500	190,0	7.480	188,0	7.402	6"	30	66
244.5-12.7	244,5	9 ⅝	12,7	0.500	216,0	8.425	214,0	8.425	8"	54	119
273-12.7	273,0	10 ¾	12,7	0.500	245,0	9.646	243,0	9.567	8"	66	146
301,6-15	301,6	11 ⅞	15,0	0.591	268,0	10.551	268,0	10.551	8"	78	172
323.9-12.7	323,9	12 ¾	12,7	0.500	295,0	11.614	294,0	11.575	8-10"	77	170
339.7-12.7	339,7	13 ⅝	12,7	0.500	311,0	12.165	309,0	12.165	8-10"	80-100	176-320
406.4-12.7	406,4	16	12,7	0.500	374,0	14.724	374,0	14.724	10-12"	180	397
457-16	457,0	18	16,0	0.630	417,0	16.417	417,0	16.417	12"	255	562
508-16	508,0	20	16,0	0.630	467,0	18.386	467,0	18.386	12-18"	450	992
609.6-19	609,6	24	19,0	0.748	562,0	22.126	562,0	22.126	18"	572	1261
711-20	711,0	28	20,0	0.787	662,0	26.063	662,0	26.063	18-24"	1000	2205
762-25.4	762,0	30	25,4	1.000	701,0	27.598	701,0	27.598	20-24"	1080	2381
813-23	813,0	32	23,0	0.906	757,0	29.803	757,0	29.803	20-24"	1220	2690
914-23	914,0	36	23,0	0.906	857,0	33.740	857,0	33.740	20-24"	1430	3153
1016-23	1016,0	40	23,0	0.906	960,0	37.795	960,0	37.795	24"	2400	5291
1220-25.4	1220,0	48	25,4	1.000	1157,0	45.551	1157,0	45.551	33"	3190	7033
1320-25.4	1320,0	52	25,4	1.000	1256,0	49.449	1256,0	49.449	33"	3900	8598
1422-25.4	1422,0	56	25,4	1.000	1357,0	53.425	1357,0	53.425	33"	4400	9700
1524-25.4	1524,0	60	25,4	1.000	1458,0	57.402	1458,0	57.402	33"	5000	11023

DTH Prime Ring Bit

Item size	Casing				Ring bit				Weight	
										
	[mm]	[in]	[mm]	[in]	[mm]	[in]	[mm]	[in]		[kg]
114.3-10	114,3	4 ½	10,0	0.394	80,0	3.150	135,0	5.315	5	10
139.7-10	139,7	5 ½	10,0	0.394	100,0	3.937	161,0	6.339	6	13
152.4-12.7	152,4	6	12,7	0.500	106,0	4.173	175,0	6.890	8	17
168.3-12.7	168,3	6 ⅝	12,7	0.500	126,0	4.961	191,0	7.520	9	19
177.8-14	177,8	7	14,0	0.551	126,0	4.961	192,0	7.559	7	15
193.7-12.7	193,7	7 ⅝	12,7	0.500	148,0	5.827	216,0	8.504	10	22
219.1-12.7	219,1	8 ⅝	12,7	0.500	172,0	6.772	241,0	9.488	12	26
244.5-12.7	244,5	9 ⅝	12,7	0.500	194,0	7.638	268,0	10.551	14	31
273-12.7	273,0	10 ¾	12,7	0.500	222,0	8.740	304,0	11.969	18	39
XL2 273-12.7	273,0	10 ¾	12,7	0.500	222,0	8.740	327,0	12.874	21	46
301,6-15	301,6	11 ⅞	15,0	0.591	245,0	9.646	328,0	12.913	20	44
323.9-12.7	323,9	12 ¾	12,7	0.500	272,0	10.709	350,0	13.780	20	45
XL2 323.9-12.7	323,9	12 ¾	12,7	0.500	272,0	10.709	377,0	14.843	24	53
339.7-12.7	339,7	13 ⅝	12,7	0.500	288,0	11.339	368,0	14.488	22	49
406.4-12.7	406,4	16	12,7	0.500	354,0	13.937	442,0	17.402	34	75
XL2 406.4-12.7	406,4	16	12,7	0.500	354,0	13.937	460,0	18.110	37	82
457-16	457,0	18	16,0	0.630	389,0	15.315	497,0	19.567	46	101
508-16	508,0	20	16,0	0.630	438,0	17.244	548,0	21.575	53	116
XL2 508-16	508,0	20	16,0	0.630	438,0	17.244	562,0	22.126	56	123
609.6-19	609,6	24	19,0	0.748	534,0	21.024	650,0	25.591	62	136
XL2 609.6-19	609,6	24	19,0	0.748	534,0	21.024	664,0	26.142	65	143
711-20	711,0	28	20,0	0.787	631,0	24.843	758,0	29.843	110	243
762-25.4	762,0	30	25,4	1.000	667,0	26.260	809,0	31.850	104	229
813-23	813,0	32	23,0	0.906	723,0	28.465	860,0	33.858	119	263
914-23	914,0	36	23,0	0.906	824,0	32.441	962,0	37.874	132	290
1016-23	1016,0	40	23,0	0.906	932,0	36.693	1068,0	42.047	180	397
1220-25.4	1220,0	48	25,4	1.000	1129,0	44.449	1272,0	50.079	221	487
1320-25.4	1320,0	52	25,4	1.000	1226,0	48.268	1374,0	54.094	250	551
1422-25.4	1422,0	56	25,4	1.000	1325,0	52.165	1476,0	58.110	270	595
1524-25.4	1524,0	60	25,4	1.000	1423,0	56.024	1580,0	62.205	300	662

DTH SR

Solitary ring system for down the hole hammer

- Economical and cost-effective to use in homogenous ground with few small boulders
- Install piles and interlocked Pipe-Pile-Wall piles with the same pilot by using different ring bits
- Available for all the common Down The Hole hammers
- Can be used for all applications where the casing is left in the ground
- Designed for piling, underpinning, and micropiling applications
- Use the same pilot bit either with separate standard ring bit and impact shoe or with an integrated ring bit where the impact shoe is pressed into the ring bit as a ring assembly



(SAME PILOT BIT WORKS WITH STANDARD & INTEGRATED RING BIT)

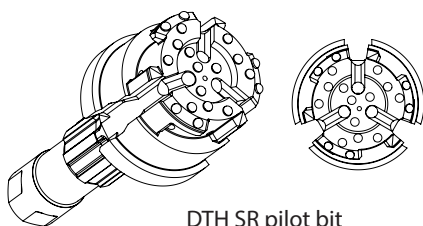

DTH SR pilot bit

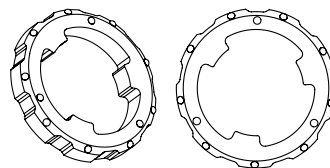

DTH SR ring bit

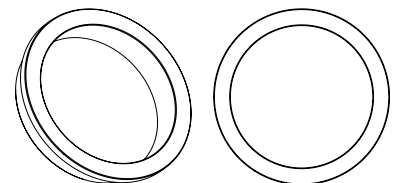

DTH SR impact shoe

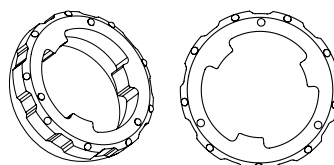

DTH SR integrated ring assembly

DTH SR Pilot Bit

Item size

Casing

Pilot bit

Hammer

Weight

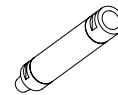

	Casing		Casing		Pilot bit		Hammer	Weight	
	[mm]	[in]	[mm]	[in]	[mm]	[in]		[kg]	[lbs]
114.3-10	114,3	4 ½	10,0	0.394	92,5	3.642	3"	7	15
139.7-10	139,7	5 ½	10,0	0.394	117,0	4.606	4"	12	26
168.3-12.7	168,3	6 ¾	12,7	0.500	140,5	5.531	5"	20	44
219.1-12.7	219,1	8 ¾	12,7	0.500	190,7	7.508	6"	36	80
273-12.7	273,0	10 ¾	12,7	0.500	244,6	9.630	8"	74	164
323.9-12.7	323,9	12 ¾	12,7	0.500	294,5	11.594	8-10"	97	215
406.4-12.7	406,4	16	12,7	0.500	376,0	14.803	10-12"	196	433
508-16	508,0	20	16,0	0.630	472,0	18.583	12"	297	655
609.6-16	609,6	24	16,0	0.630	571,0	22.480	18"	670	1477
711-16	711,0	28	16,0	0.630	671,0	26.417	24"	730	1610
813-23	813,0	32	23,0	0.906	758,0	29.843	20-24"	1080	2381
863-23	863,0	34	23,0	0.906	808,0	31.811	20-24"	1100	2425
914-23	914,0	36	23,0	0.906	858,0	33.780	20-24"	1500	3307
1016-23	1016,0	40	23,0	0.906	959,0	37.756	24"	1800	3968
1220-25.4	1220,0	48	25,4	1.000	1156,0	45.512	33"	2500	5512
1320-25.4	1320,0	52	25,4	1.000	1256,0	49.449	33"	3500	7716
1422-25.4	1422,0	56	25,4	1.000	1357,0	53.425	33"	4000	8819
1524-25.4	1524,0	60	25,4	1.000	1458,0	57.402	33"	4600	10141

DTH SR Ring Bit

Item size

Casing

Ring bit

Weight



	Casing		Casing		Ring bit		Ring bit		Standard		Integrated	
	[mm]	[in]	[mm]	[in]	[mm]	[in]	[mm]	[in]	[kg]	[lbs]	[kg]	[lbs]
114.3-10	114,3	4 ½	10,0	0.394	61,0	2.401	125,0	4.921	2	4	-	-
139.7-10	139,7	5 ½	10,0	0.394	82,0	3.228	150,0	5.906	3	7	-	-
168.3-12.7	168,3	6 ¾	12,7	0.500	102,0	4.016	182,0	7.165	7	15	-	-
219.1-12.7	219,1	8 ¾	12,7	0.500	127,0	5.000	233,0	9.173	10	22	-	-
XL2 219.1-12.7	219,1	8 ¾	12,7	0.500	127,0	5.000	273,0	10.748	15	33	-	-
273-12.7	273,0	10 ¾	12,7	0.500	194,0	7.638	287,0	11.299	13	29	-	-
XL2 273-12.7	273,0	10 ¾	12,7	0.500	194,0	7.638	327,0	12.874	19	41	-	-
323.9-12.7	323,9	12 ¾	12,7	0.500	240,0	9.449	338,0	13.307	16	35	-	-
XL2 323.9-12.7	323,9	12 ¾	12,7	0.500	240,0	9.449	378,0	14.882	23	50	-	-
406.4-12.7	406,4	16	12,7	0.500	322,0	12.677	420,0	16.535	21	45	26	57
XL2 406.4-12.7	406,4	16	12,7	0.500	322,0	12.677	460,0	18.110	31	67	36	79
508-16	508,0	20	16,0	0.630	417,0	16.417	522,0	20.551	27	59	32	70
XL2 508-16	508,0	20	16,0	0.630	417,0	16.417	562,0	22.126	37	81	45	99
609.6-19	609,6	24	19,0	0.748	508,0	20.000	625,0	24.606	40	88	45	99
XL2 609.6-19	609,6	24	19,0	0.748	508,0	20.000	664,0	26.142	53	116	63	139
711-16	711,0	28	16,0	0.630	616,0	24.252	726,0	28.583	44	97	60	132
XL2 711-16	711,0	28	16,0	0.630	616,0	24.252	765,0	30.118	58	128	-	-
813-23	813,0	32	23,0	0.906	705,0	27.756	828,0	32.598	60	132	76	167
XL2 813-23	813,0	32	23,0	0.906	705,0	27.756	867,0	34.134	60	132	-	-
863-23	863,0	34	23,0	0.906	742,0	29.213	875,0	34.449	57	126	85	187
914-23	914,0	36	23,0	0.906	795,0	31.299	930,0	36.614	80	177	100	220
1016-23	1016,0	40	23,0	0.906	890,0	35.039	1035,0	40.748	95	210	118	260
1220-25.4	1220,0	48	25,4	1.000	1080,0	42.520	1240,0	48.819	115	254	165	363
1320-25.4	1320,0	52	25,4	1.000	1185,0	46.654	1339,0	52.717	110	243	190	419
1422-25.4	1422,0	56	25,4	1.000	1283,0	50.512	1440,0	56.693	125	276	215	474
1524-25.4	1524,0	60	25,4	1.000	1379,0	54.291	1542,0	60.709	145	320	250	551

For impact shoe sizes, please see the next spread.

DTH SF (STEEL FIST)

Steel Fist system for down the hole hammer

- Designed for specific piling operations, sizes from 273 mm up to 1220 mm
- New economic way for traditional piling work
- Capable of installing water-proof Pipe-Pile-Walls
- No ring bit is needed when piling with DTH SF
- Usage in homogenous soil conditions with small boulders
- Available for all the common Down The Hole hammers
- Can be used for all applications where the casing is left in the ground
- Ideal for piling and installing Pipe-Pile-Walls

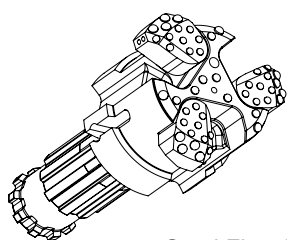
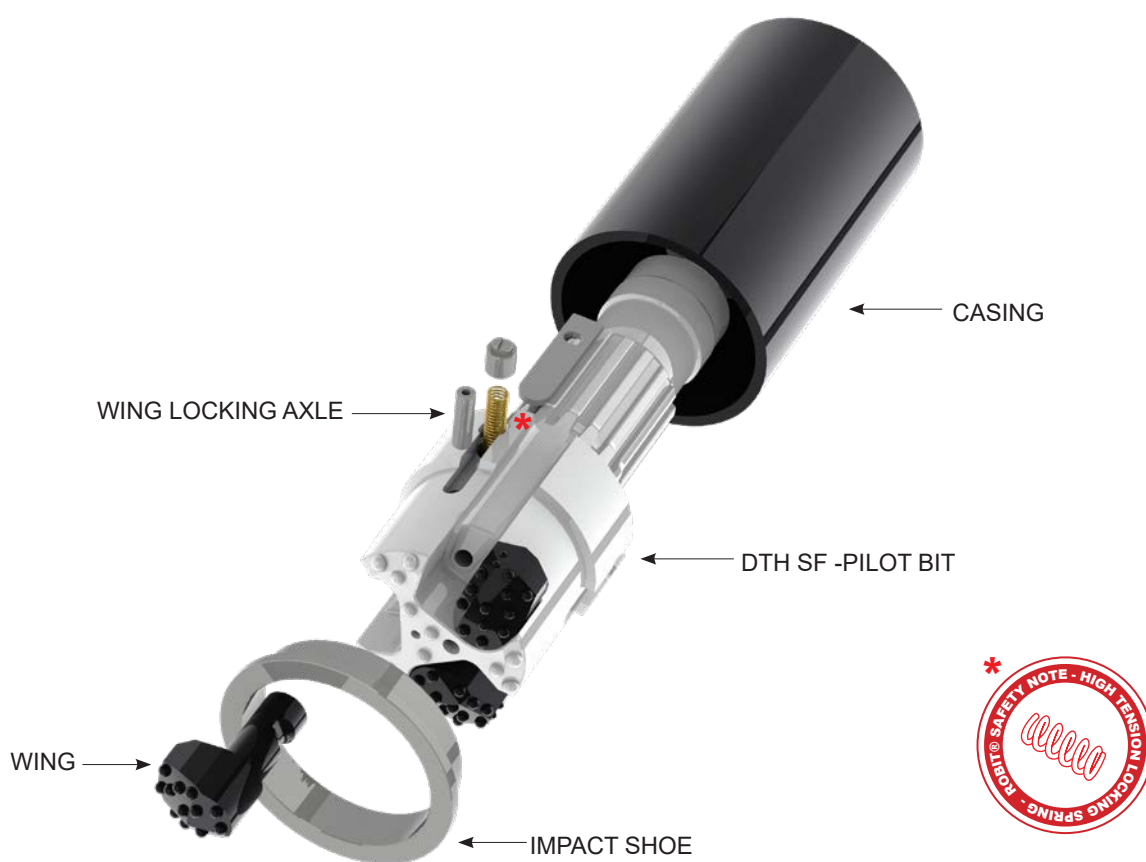

Steel Fist pilot bit

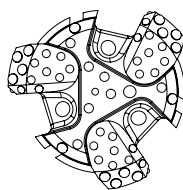

Steel Fist impact shoe

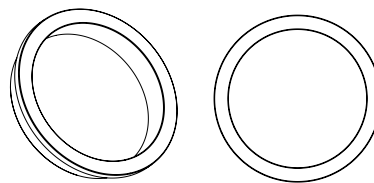

DTH SF

Item size

Pipe

Pilot bit

Wings

Hammer

Weight



	Pipe		Pipe		Pilot bit		Pilot bit		Wings	Hammer	Weight	
	[mm]	[in]	[mm]	[in]	[mm]	[in]	[mm]	[in]	[pcs]		[kg]	[lbs]
273-12.7	273,0	10 ¾	12,7	0.500	287,0	11.299	245,0	9.646	3	8"	86	190
323.9-12.7	323,9	12 ¾	12,7	0.500	338,0	13.307	294,5	11.594	3	8"	118	259
XL2 323.9-12.7	323,9	12 ¾	12,7	0.500	374,0	14.724	294,5	11.594	3	8"	128	282
406.4-12.7	406,4	16	12,7	0.500	420,0	16.535	376,0	14.803	3	10-12"	216	476
XL2 406.4-12.7	406,4	16	12,7	0.500	460,0	18.110	376,0	14.803	3	10-12"	228	503
508-16	508,0	20	16,0	0.630	522,0	20.551	472,0	18.583	3	12"	353	778
XL2 508-16	508,0	20	16,0	0.630	562,0	22.126	472,0	18.583	3	12"	365	805
609.6-16	609,6	24	16,0	0.630	624,0	24.567	571,0	22.480	3	18"	807	1778
XL2 609.6-16	609,6	24	16,0	0.630	664,0	26.142	571,0	22.480	3	18"	820	1808
711-16	711,0	28	16,0	0.630	725,0	28.543	671,0	26.417	3	18"	1090	2403
XL2 711-16	711,0	28	16,0	0.630	765,0	30.118	671,0	26.417	3	18"	1095	2414
813-23	813,0	32	23,0	0.906	826,0	32.520	758,0	29.843	3	18"	1456	3210
XL2 813-23	813,0	32	23,0	0.906	867,0	34.134	758,0	29.843	3	18"	1472	3244
914-20	914,0	36	20,0	0.787	927,0	36.496	864,0	34.016	4	24-30"	1750	3858
XL2 914-20	914,0	36	20,0	0.787	968,0	38.110	864,0	34.016	4	24-30"	1770	3902
1016-16	1016,0	40	16,0	0.630	1030,0	40.551	973,0	38.307	5	24-33"	2050	4518
XL2 1016-16	1016,0	40	16,0	0.630	1070,0	42.126	973,0	38.307	5	24-33"	2080	4586
1220-20	1220,0	48	20,0	0.787	1234,0	48.583	1135,0	44.685	6	30-33"	2970	6548
XL2 1220-20	1220,0	48	20,0	0.787	1274,0	50.157	1135,0	44.685	6	30-33"	3000	6614

When ordering, information about casing diameters (OD and ID) is necessary.

DTH SR / SF Impact Shoe

Item size

Pipe

Impact shoe

Weight



	Pipe		Pipe		Impact shoe		Weight	
	[mm]	[in]	[mm]	[in]	[mm]	[in]	[kg]	[lbs]
114.3-10	114,3	4 ½	6,3-10,0	0.248-0.394	80,5	3.169	1	2
139.7-10	139,7	5 ½	6,3-10,0	0.248-0.394	103,5	4.075	1	2
168.3-12.7	168,3	6 ⅝	6,3-12,7	0.248-0.500	122,4	4.819	2	4
219.1-12.7	219,1	8 ⅝	6,3-12,7	0.248-0.500	173,0	6.811	3	7
273-12.7	273,0	10 ¾	6,3-12,7	0.248-0.500	226,0	8.898	5	11
323.9-12.7	323,9	12 ¾	6,3-12,7	0.248-0.500	277,0	10.906	6	13
406.4-12.7	406,4	16	6,3-12,7	0.248-0.500	360,0	14.173	8	18
508-16	508,0	20	8,0-16,0	0.315-0.630	456,0	17.953	10	22
609.6-19	609,6	24	8,0-19,0	0.315-0.748	553,0	21.772	13	29
711-16	711,0	28	8,0-16,0	0.315-0.630	654,0	25.748	15	33
813-23	813,0	32	8,0-23,0	0.315-0.906	740,0	29.134	30	66
914-20	914,0	36	10,0-20,0	0.394-0.787	836,0	32.913	35	77
1016-16	1016,0	40	10,0-16,0	0.394-0.630	937,0	36.890	40	88
1220-20	1220,0	48	10,0-20,0	0.394-0.787	1135,0	44.685	50	110

CASING SYSTEMS FOR WELL DRILLING

Casing Systems for Well Drilling

Versatile casing system solutions, which are centered around well drilling but offer excellent choices for also other operations. Choose between integrated ring bit system for challenging conditions and an eccentric system for overburden drilling. Well drilling systems are optimized for thin wall casing offering maximal drill-through diameter.

Suitable applications:

- Water well drilling
- Thermal well drilling
- Micropiling
- Dam and port projects



Robit® DTH Nova



Robit® DTH-REC



picture: Rototec

DTH Nova

Single-use system for down the hole hammer

- Ideal for overburden that is thick and full of boulders
- Enables easy, fast, and reliable drilling process in all conditions
- Available for all the common down the hole hammers
- Designed for all applications where the casing is left in the ground
- Highly suitable for the drilling of both water wells and thermal wells

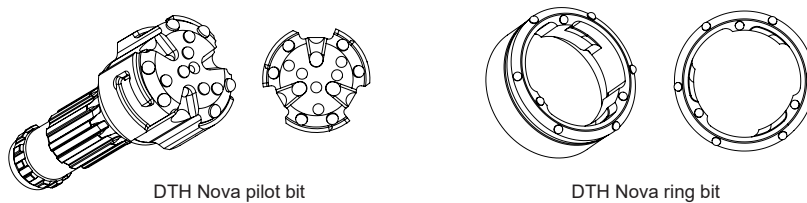

Nova Pilot bit ID optimized

Item size	Casing				Pilot bit		Hammer	Weight	
	[mm]	[in]	[mm]	[in]	[mm]	[in]		[kg]	[lbs]
114.3-5	114,3	4 ½	5,0	0.197	102,0	4.016	3 ½"	7	15
139.7-5.6	139,7	5 ½	5,6	0.220	127,0	5.020	4"	12	27
168.3-6	168,3	6 ⅝	6,0	0.236	155,0	6.102	5"	19	42
193.7-6	193,7	7 ⅝	6,0	0.236	180,0	7.087	6"	30	66
219.1-6	219,1	8 ⅝	6,0	0.236	205,0	8.071	6"	38	84
273-8	273,0	10 ¾	8,0	0.315	255,0	10.039	8"	69	152
323.9-8	323,9	12 ¾	8,0	0.315	305,0	12.047	8"	89	196

Nova Ring bit ID optimized

Item size	Casing				Ring bit				Weight	
	[mm]	[in]	[mm]	[in]	[mm]	[in]	[mm]	[in]	[kg]	[lbs]
114.3-5	114,3	4 ½	5,0	0.197	91,0	3.583	135,0	5.314	3	7
139.7-5.6	139,7	5 ½	5,6	0.220	116,0	4.567	161,0	6.339	3	7
168.3-6	168,3	6 ⅝	6,0	0.236	142,0	5.591	191,0	7.520	6	13
193.7-6	193,7	7 ⅝	6,0	0.236	168,0	6.614	216,0	8.504	7	15
219.1-6	219,1	8 ⅝	6,0	0.236	192,0	7.559	241,0	9.488	8	18
273-8	273,0	10 ¾	8,0	0.315	242,0	9.528	304,0	11.969	13	29
323.9-8	323,9	12 ¾	8,0	0.315	281,0	11.063	350,0	13.780	16	35

DTH-REC

Robit® Overburden Eccentric System

- Designed to offer maximum reliability in overburden drilling conditions
- Enables driving the casing in all downward vertical directions/formations
- Helps avoid collapsing holes and lost equipment
- A two-piece bit, consisting of a concentric pilot bit and a swing-out eccentric reamer
- Enlarges the hole's diameter driving the casing down into the hole
- Reamer can be retracted by applying reverse rotation
- Full system can be pulled out and used again
- Ideal for water well and geothermal drilling, micropiling, as well as dam and port projects

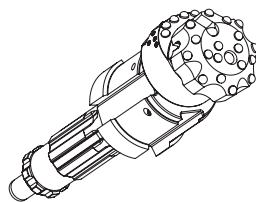
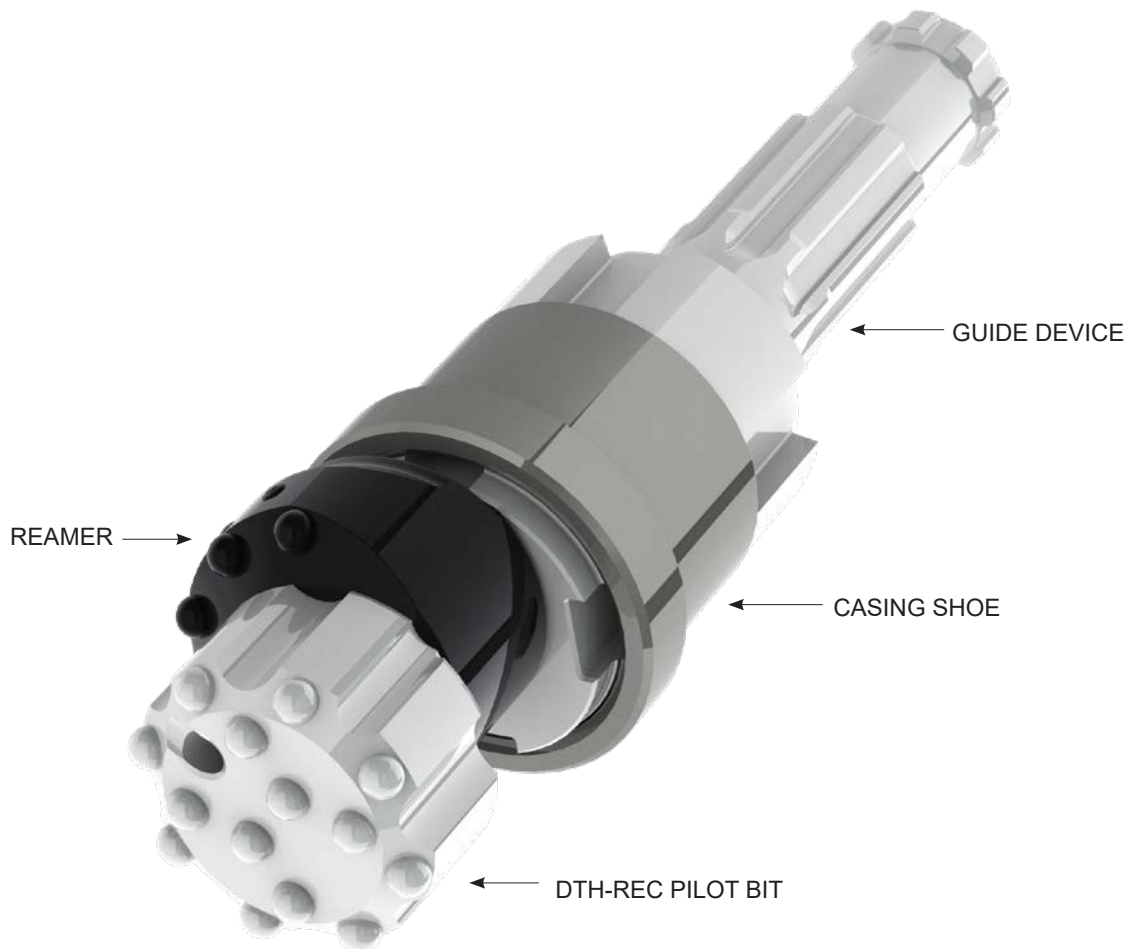

DTH-REC pilot bit

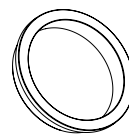

DTH-REC impact casing bit

DTH-REC

Order code

Pipe

Guide device OD

Pilot bit open

Hammer

Weight

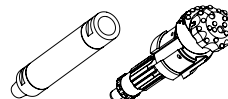

Order code	Pipe		Pipe		Guide device OD		Pilot bit open		Hammer	Weight			
	[mm]	[in]	[mm]	[in]	[mm]	[in]	[mm]	[in]		[kg]	[lbs]	[kg]	[lbs]
114.3-6	114,3	4 ½	6,0	0.236	99,5	3.917	125,0	4.921	3"	12	27	1	3
139.7-5.6	139,7	5 ½	5,6	0.220	125,5	4.941	153,0	6.023	4"	22	49	2	4
168.3-5.6	168,3	6 ⅝	5,6	0.220	154,0	6.063	185,0	7.283	5"	36	79	3	6
193.7-5	193,7	7 ⅝	5,0	0.196	179,0	7.047	212,0	8.346	6"	57	126	4	8
219.1-6.3	219,1	8 ⅝	6,3	0.248	203,0	7.992	238,0	9.370	6"	79	174	4	9
273-6.3	273,0	10 ¾	6,3	0.248	255,0	10.039	307,0	12.086	8"	136	300	7	14

* Casing shoe wall thickness

**Complete System does not include Casing shoes

Component parts

Ref	Description	Item number					
		114,3/6 IR3,5	139,7/5,6 IR340	168,3/6,3 IR350	193,7/6,3 IR360	219,1/6,3 IR360	273/6,3 IR380
1	Guide device	2000272	2000179	2000064	2000329	2000249	03-581-273-0049
2	Locking kit	2000283	2000219	2000226	2000335	2000259	2000361
3	Reamer	2000276	2000184	2000060	2000333	2000254	03-620-273-0047
4	Pilot bit	2000274	2000182	2000062	2000331	2000252	03-610-273-0052
5	Casing shoe	2000281 (6)*	2000187 (5,6)*	2000508 (6,3)*	2000509 (6,3)*	2000255 (6,3)*	03-630-273-0054 (6,3)*
6	Casing shoe	2000282 (4,5)*	2000201 (4,5)*	2000058 (5,6)*	2000336 (5)*	2000256 (5)*	-
7	Casing shoe	-	-	2000203 (4,5)*	-	-	-
	Complete System**	2000499	2000500	2000501	2000502	2000498	2000503

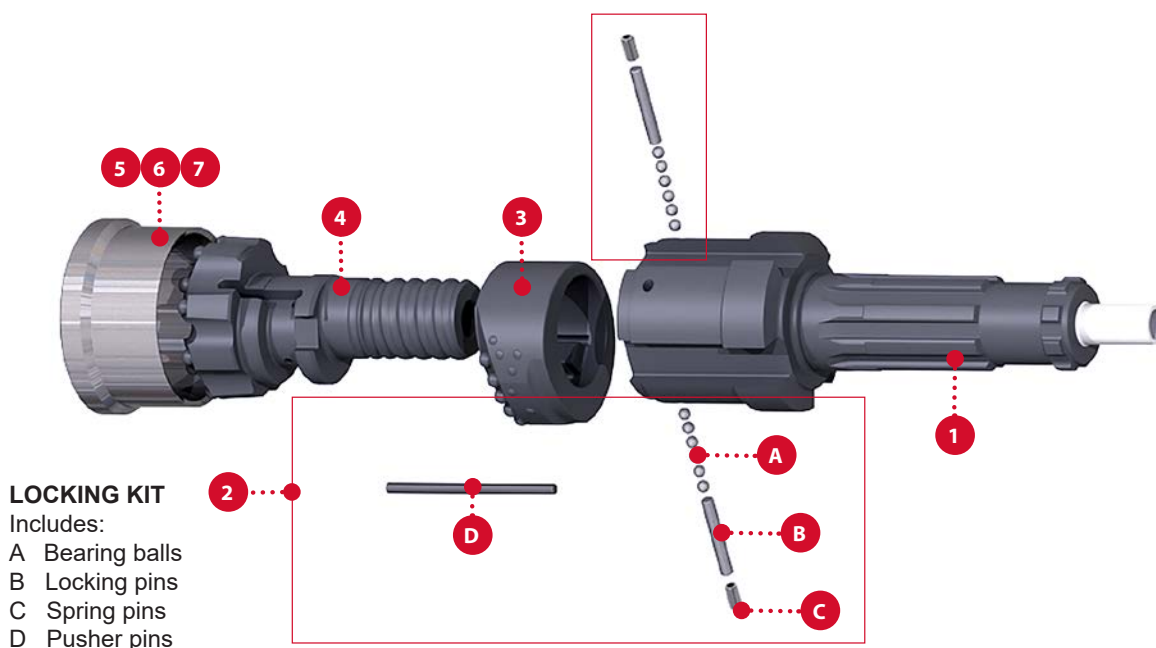

MULTI-PURPOSE CASING SYSTEMS

Casing Systems for Multi-purpose Systems

Durable casing systems specifically designed for applications where the casing has to be removed from the ground. Created for extremely demanding conditions.

Suitable applications:

- Piling
- Anchoring
- Site investigation

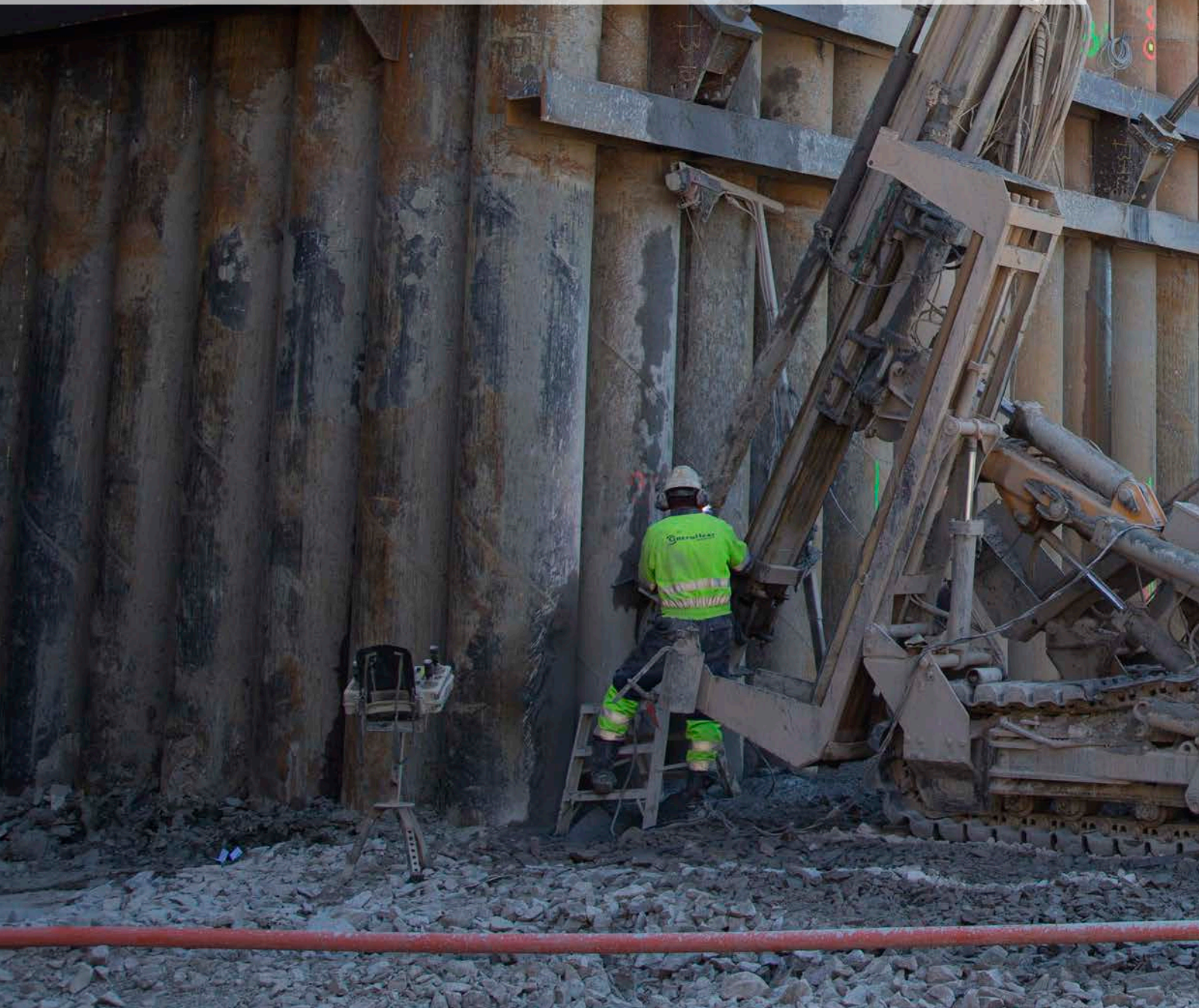

Robit® DTH-RoX MU



DTH-RoX MU

Multi-use system for down the hole hammer

- Made for applications where the casing has to be removed from the ground.
- Designed to meet durability standards for removable equipment
- Double groove design* in the casing shoe
- Made using the best materials available
- Available for all the common down the hole hammers
- Ideal for piling, anchoring, and site investigation

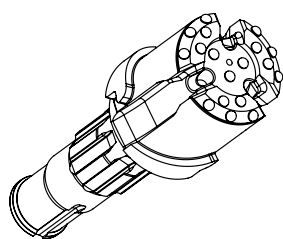

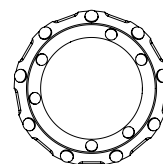
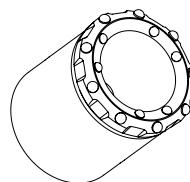
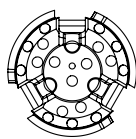

DTH-RoX Multi-Use pilot bit





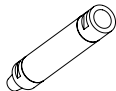
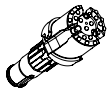

DTH-RoX Multi-Use ring bit

DTH-RoX MU Pilot bit

Item size	Casing				Pilot bit		Hammer	Weight	
									
	[mm]	[in]	[mm]	[in]	[mm]	[in]		[kg]	[lbs]
114.3-10	114,3	4 ½	10,0	0.394	92,5	3.642	3"	7	14
127-10	127,0	5	10,0	0.394	105,2	4.142	3 ½"	9	20
139.7-10	139,7	5 ½	10,0	0.394	117,5	4.626	4"	13	29
152.4-10	152,4	6	10,0	0.394	130,6	5.142	4"	17	37
168.3-10	168,3	6 ⅝	10,0	0.394	146,0	5.748	5"	22	48
177.8-10	177,8	7	10,0	0.394	155,0	6.102	5"	28	61
193.7-10	193,7	7 ⅝	10,0	0.394	172,0	6.772	6"	35	77
219.1-12.7	219,1	8 ⅝	12,7	0.500	192,0	7.717	6"	40	88
273-12.7	273,0	10 ¾	12,7	0.500	243,0	9.567	8"	80	177
323.9-12.7	323,9	12 ¾	12,7	0.500	293,0	11.535	8"	120	265
355.6-12.7	355,6	14	12,7	0.500	326,0	12.835	8-12"	174	383
406.4-12.7	406,4	16	12,7	0.500	374,0	14.724	10-12"	236	520
508-15	508,0	20	15,0	0.591	472,0	18.583	12-15"	540	1191
609.6-12.7	609,6	24	12,7	0.500	581,0	22.874	18"	780	1720

DTH-RoX MU Ring bit

Item size	Casing				Ring bit				Weight	
										
	[mm]	[in]	[mm]	[in]	[mm]	[in]	[mm]	[in]	[kg]	[lbs]
114.3-10	114,3	4 ½	10,0	0.394	78,0	3.071	122,0	4.803	6	12
127-10	127,0	5	10,0	0.394	95,0	3.740	136,0	5.354	7	14
139.7-10	139,7	5 ½	10,0	0.394	104,0	4.094	147,0	5.787	8	17
152.4-10	152,4	6	10,0	0.394	115,8	4.559	159,5	6.280	9	20
168.3-10	168,3	6 ⅝	10,0	0.394	129,0	5.079	178,0	7.008	11	24
177.8-10	177,8	7	10,0	0.394	142,0	5.591	191,0	7.520	12	26
193.7-10	193,7	7 ⅝	10,0	0.394	154,0	6.063	204,0	8.031	14	30
219.1-12.7	219,1	8 ⅝	12,7	0.500	172,0	6.772	229,0	9.016	17	37
273-12.7	273,0	10 ¾	12,7	0.500	211,0	8.307	286,0	11.260	32	71
323.9-12.7	323,9	12 ¾	12,7	0.500	257,0	10.118	338,0	13.307	51	113
355.6-12.7	355,6	14	12,7	0.500	305,0	12.008	368,0	14.488	47	104
406.4-12.7	406,4	16	12,7	0.500	328,0	12.913	423,0	16.654	75	166
508-15	508,0	20	15,0	0.591	414,0	16.299	526,0	20.709	120	265
609.6-12.7	609,6	24	12,7	0.500	554,0	21.811	645,0	25.394	150	331



DTH BITS

GENERAL PURPOSE BITS

DTH Bits

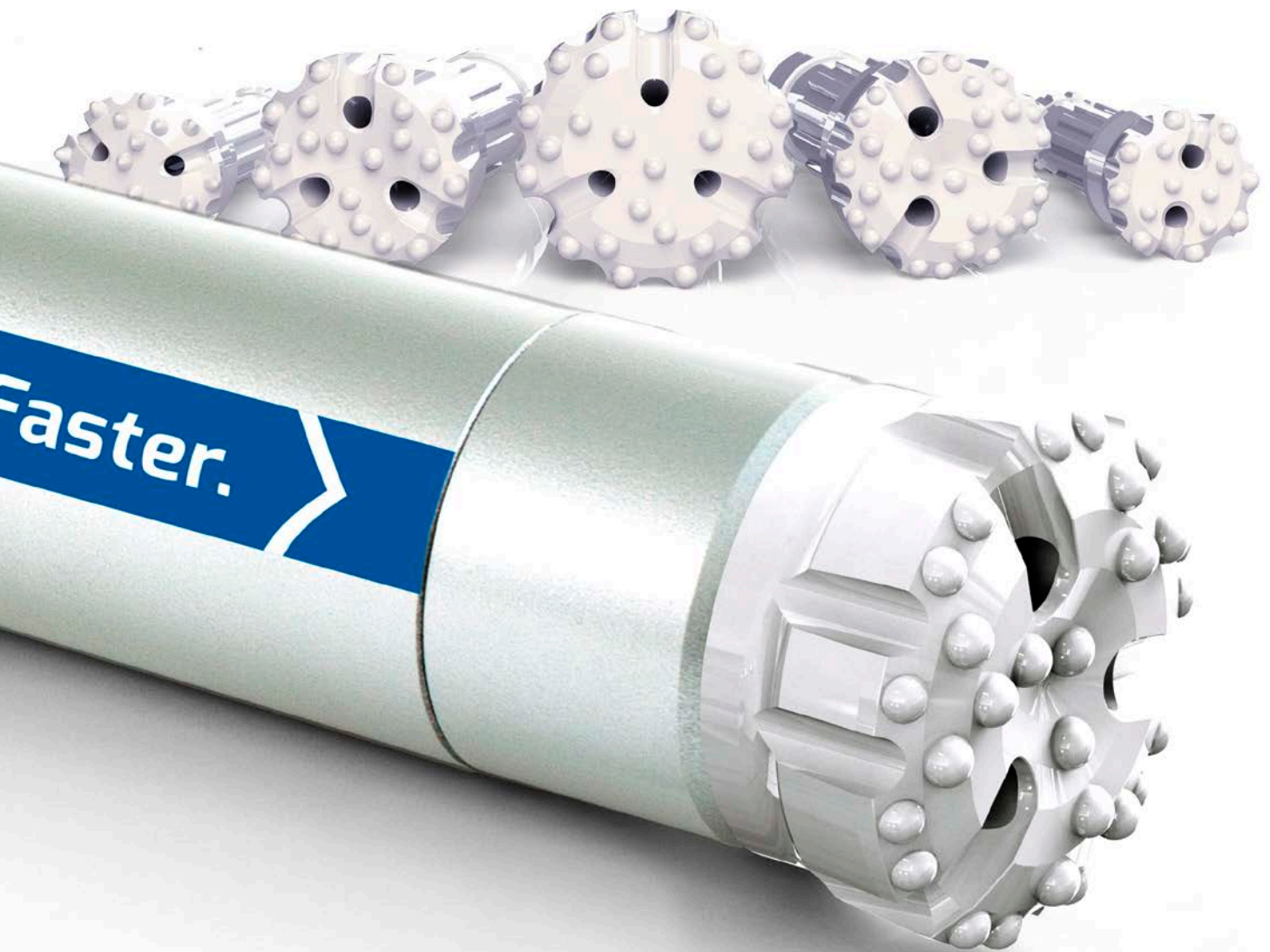

BIT SELECTION GUIDE

Geotechnical

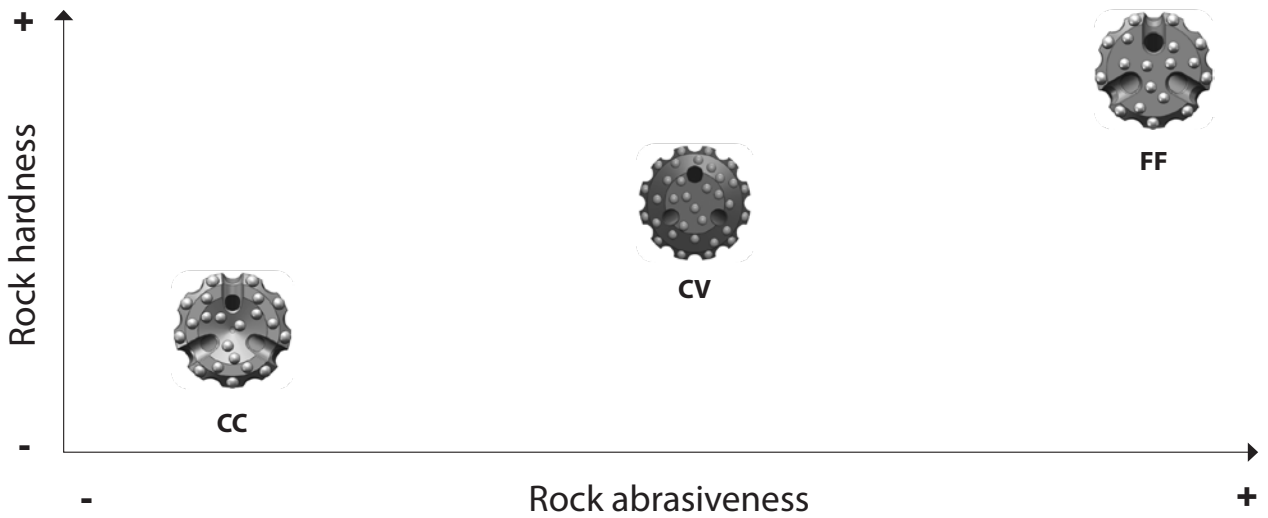

DTH Bits

Conventional Bits



Flat Face - FF

- Common face design in global market
- Excellently performing bit
- Hard to very hard rock
- Solid consistent formation



Concave - CC

- Common face design in global market
- Excellent deviation control
- Medium hard to hard rock
- Broken and sloped angled formation

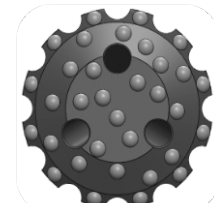

Convex - CV

- Common in global market
- Excellent penetration rate
- Medium / hard formation
- Shales / sandstone formations

New DTH Drill Bit Description

Example: DTH BIT 165 QL60 FF H1

DTH BIT	165	QL60		FF		H	1
Product Group	Head Diameter	Shank Type	Footvalve	Face Type	Other	Carbide Profile	Carbide Grade
						If different carbide profile or grade in gauge and face, then 1st code will represent the gauge, 2nd the face	
DTH BIT	165	DHD3.5	TL = Tubeless	FF = Flat Face	RET = Retention	H = Hemispherical	1 = Majority of Applications
DTH HAMMER		TD40	Blank = Standard Footvalve	CC = Concave	GEN2 = 2nd Generation	SB = Semi Ballistic	2 = Very Hard Ground
DTH PIPE		DHD340		CV = Convex		FB = Full Ballistic	3 = Underground Iron Ore
		QL50		DC = Drop Center		C = Conical	4 = Very High Abrasive
		DHD350		XHF = Extra Hard Formation			5 = Polycrystalline Diamond
		QL60		HFDC = Hard Formation Drop Center			
		DHD360		DRG = Double Gauge Row			
		QL80					
		DHD380					

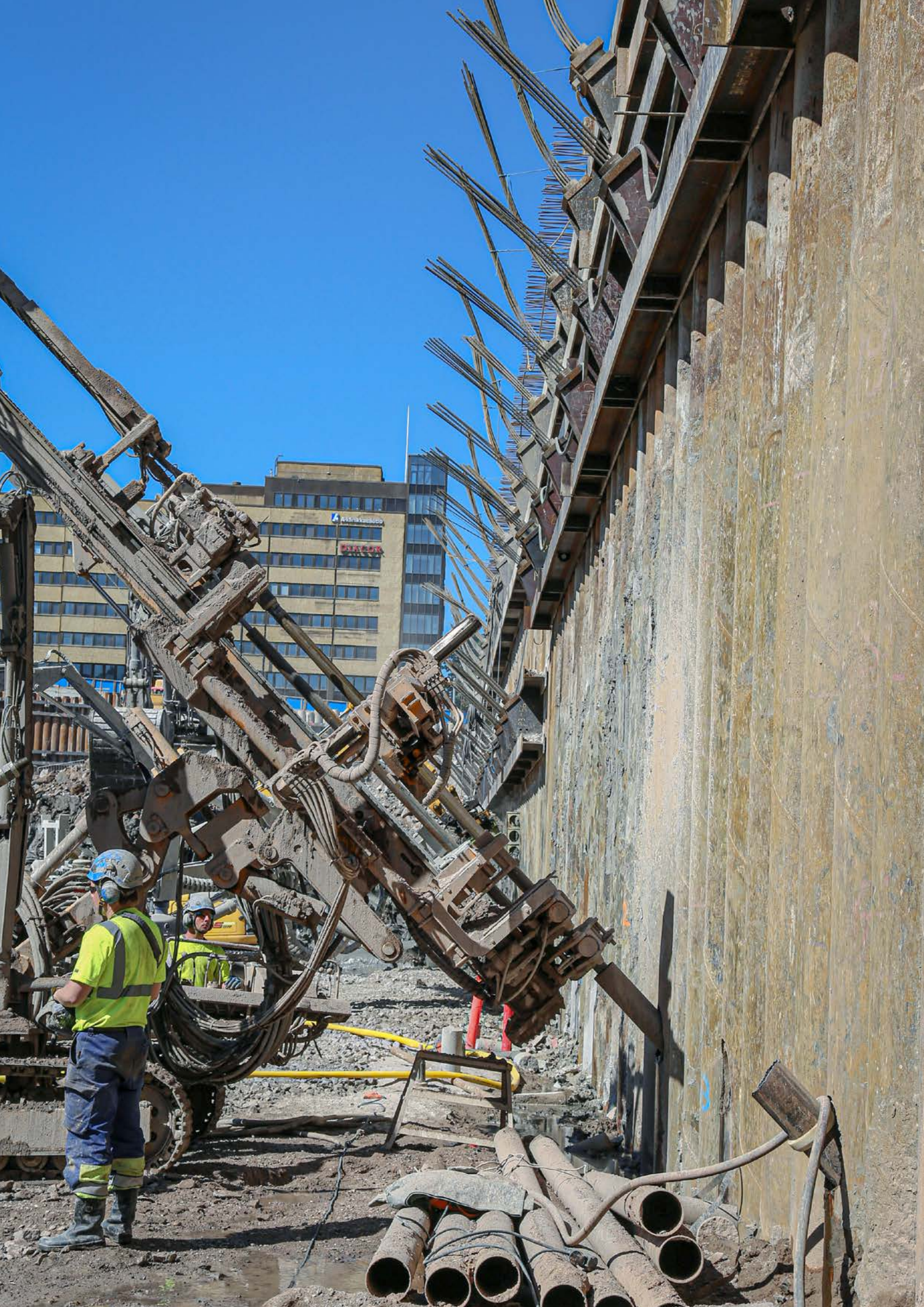

DTH BITS

STANDARD BIT SIZES

Order code	DTH Hammer	Diameter		Weight*	Face type		
		[mm]	[in]		Flat	Convex	Concave
DTH-Bit 90/3"	3"	90	3 ½	3,4		x	
DTH-Bit 95/3"	3"	95	3 ¾	3,8		x	
DTH-Bit 100/3"	3"	100	4	4,4		x	
DTH-Bit 105/4"	4"	105	4 ⅛	8,4		x	
DTH-Bit 110/4"	4"	110	4 ⅜	8,8	x	x	
DTH-Bit 115/4"	4"	115	4 ½	9	x	x	
DTH-Bit 127/4"	4"	127	5	9,9	x	x	
DTH-Bit 127/5"	5"	127	5	15,6	x	x	
DTH-Bit 140/5"	5"	140	5 ½	17,4	x	x	
DTH-Bit 152/5"	5"	152	6	18,9	x	x	
DTH-Bit 152/6"	6"	152	6	25,5	x		x
DTH-Bit 165/6"	6"	165	6 ½	26,3	x		x
DTH-Bit 200/8"	8"	200	7 ⅞	33,8			x
DTH-Bit 203/6"	6"	203	7	32,6	x		x
DTH-Bit 203/8"	8"	203	7	34,5			x
DTH-Bit 216/6"	6"	216	8 ½	34,4	x		x
DTH-Bit 216/8"	8"	216	8 ½	37,5			x
DTH-Bit 254/8"	8"	254	10	51,5			x
DTH-Bit 305/12"	12"	305	12	159			x
DTH-Bit 311/12"	12"	311	12 ¼	166			x
DTH-Bit 381/12"	12"	381	15	233			x
DTH-Bit 445/12"	12"	445	17 ½	312			x
DTH-Bit 445/14"	14"	445	17 ½	396			x
DTH-Bit 457/14"	14"	457	18	401			x
DTH-Bit 457/18"	18"	457	18	556			x
DTH-Bit 508/14"	14"	508	20	484			x
DTH-Bit 508/18"	18"	508	20	589			x
DTH-Bit 559/14"	14"	559	22	525			x
DTH-Bit 559/18"	18"	559	22	635			x
DTH-Bit 584/18"	18"	584	23	692			x
DTH-Bit 610/18"	18"	610	24	718			x
DTH-Bit 610/24"	24"	610	24	985			x
DTH-Bit 660/24"	24"	660	26	1058			x
DTH-Bit 711/24"	24"	711	28	2475			x
DTH-Bit 762/24"	24"	762	30	2622			x
DTH-Bit 813/24"	24"	813	32	3225			x
DTH-Bit 866/24"	24"	866	34	3410			x

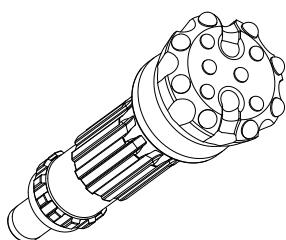

Flat face

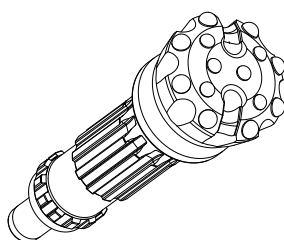

Convex face

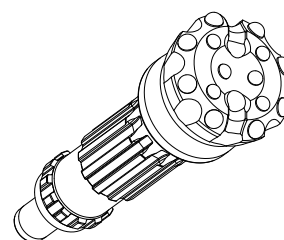

Concave face

*Weight varies based on shank, face and button design.



DTH HAMMERS

BR series hammer

H series hammers

Hyper series hammers

BR2 for small diameter drilling

- Proven small-diameter design
- Legacy engineering and design

H series for variable piling and well-drilling projects

- Lower fuel consumption
- Best in class performance
- Guaranteed operational savings
- Unbeatable in all conditions

Please contact Robit's sales regarding the



DTH hammers: sales@robitgroup.com



DTH Hammers

Hyper series for general purpose drilling

- Robust hammers of simple design to provide maximum performance with minimal maintenance
- Offered in a wide range of sizes 3"-33"
- Used globally e.g. in demanding construction and foundation projects



Components

The modular Robit H Series hammer family is available in 4", 5", 6" and 8" size ranges. Version alternatives are:

- Standard offering Heavy Duty (HD) and Slim Line (SL) with reduced OD
- Standard offering Foot Valved (FV) and Tubeless (TL) using bits without foot valves
- Maximum Performace (MX) with high output inner cylinder and High Efficiency (HF) with reduced air consumption maximizing fuel efficiency

Shank and thread connections are size specific.

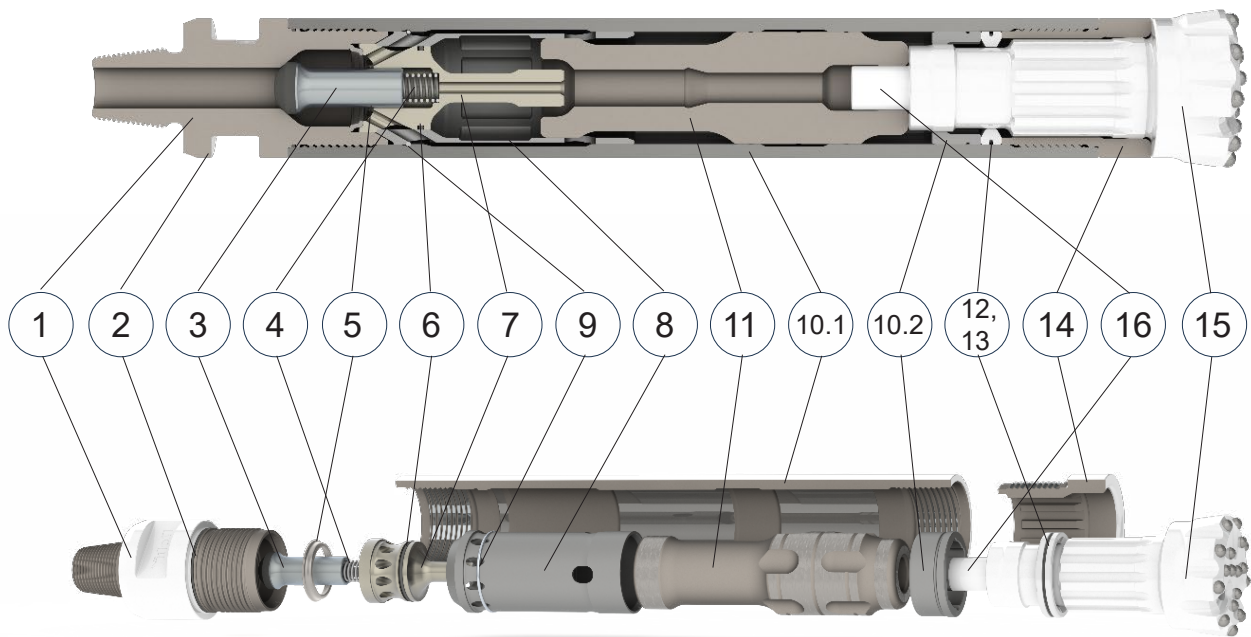

1	Backhead (Top adapter)	5	Make up ring	9	Snap ring	13	Bit retaining ring
2	Backhead (Top adapter) O-ring	6	Air distributor O-ring	10.1	Wear sleeve	14	Drive chuck
				10.2	Guide bush		
3	Check valve	7	Air distributor	11	Piston	15	DTH bit
4	Check valve spring	8	Inner cylinder	12	Bit retaining ring O-ring	16	Foot valve

Hammer Kits

The following H series kits are available:

- **Service kit**, includes components: 2, 4, 6 and 12
- **Repair kit**, includes components: 2, 3, 4, 5, 6, 12, 13 and 14
- **Life kit**, includes components: 1, 10.1, 10.2 and 14

Dismantling the hammer

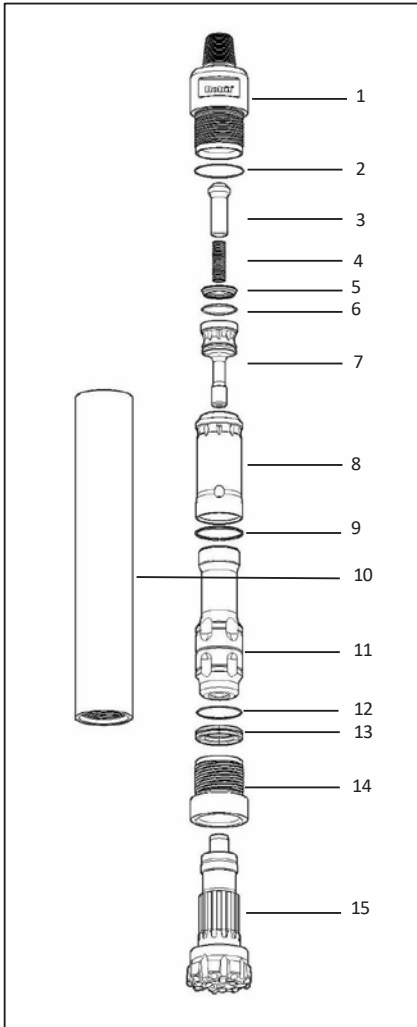

A, When dismantling hammers it is essential that the wear sleeve is clamped in the correct position.

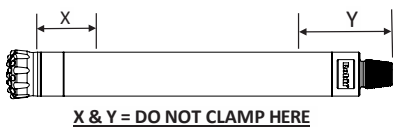

DIMENSION	X		Y	
	mm	Inches	mm	Inches
H4	140	5.5	240	9.8
H5	160	6.3	270	11.0
H6	160	6.3	310	12.7
H8	210	8.3	345	14.1

B, Break the top joint between Back head (1) and Wear Sleeve (10) and bottom joint between Chuck (14) and Wear Sleeve (10).

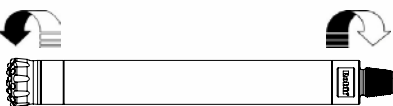

C, Unscrew and remove Drill Bit (15), Drive Sub (14) and Bit Retaining Rings (13) from Cylinder (10).

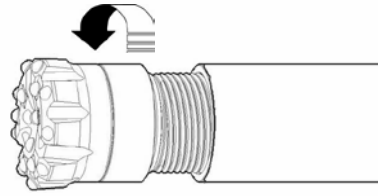

D, Remove Bit Retaining Ring (13) from Drill bit (15). Remove 'O' Ring (12) from Bit Retaining Ring (13).

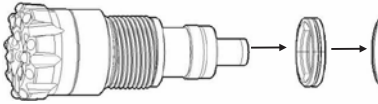

E, Remove Chuck (14) from Drill Bit (15).

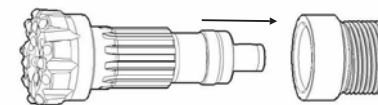

F, Unscrew and remove Back Head (1) from Wear Sleeve (10).

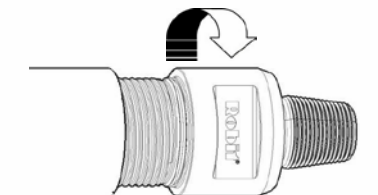

G, Remove 'O' Ring (2) from Back Head (1).



H, Remove Check Valve (3) and Chuck Valve Spring (4) from Wear Sleeve (10).

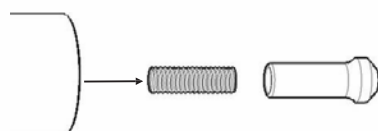

I, Remove Make Up Ring (5) from Wear Sleeve (10).

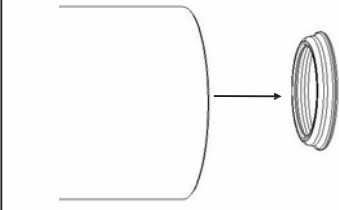

J, Remove Air Distributor (7) from Wear Sleeve (10). Remove 'O' Ring (6) from Air Distributor (7).

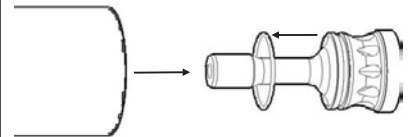

K, Remove Inner Cylinder (8) from Wear Sleeve (10).

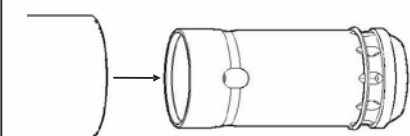

L, Remove Piston (11) from Wear Sleeve (10).

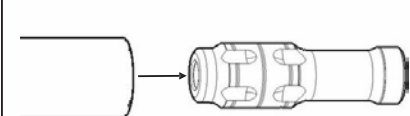

HAMMER RE-ASSEMBLY IS REVERSAL OF DISASSEMBLY.



DTH HAMMERS

BR, H & HYPER SERIES HAMMERS

Order code	DTH Hammer	Shank	Backhead thread	Wear sleeve outside diam.		Length		Weight		Piston weight	
				[mm]	[in]	[mm]	[in]	[kg]	[lbs]	[kg]	[lbs]
BR2	2"	BR2	RD50	62,0	2.441	838,0	32.992	13	29	1,8	4
Hyper 31	3"	IR3,5	2 ¾ reg pin	79,2	3.118	832,0	32.756	22,5	50	4,9	11
H4 HD	4"	TD40 DHD340	3 ¾ reg pin	102,0	4.016	860,0	33.858	38.0	84	8,4	18.5 (FV) 8,1 17,9 (TL)
H4 SL	4"	TD40 DHD340	3 ¾ reg pin	98,0	3.858	860,0	33.858	34.0	75	8,4	18.5 (FV) 8,1 17.9 (TL)
H5 HD	5"	QL50 DHD350	3 ½ reg pin	126,0	4.961	915,0	36.024	61.5	136	13,9	30.6 (FV) 11,8 26.0 (TL)
H5 SL	5"	QL50 DHD350	3 ½ reg pin	120,0	4.724	915,0	36.024	54.0	119	13,9	30.6(FV) 11,8 26.0 (TL)
H6 HD	6"	QL60 DHD360	3 ½ reg pin	146,0	5.748	1014,0	39.921	74.5	164	20,5	45.2 (FV) 20,1 44.3 (TL)
H6 SL	6"	QL60 DHD360	3 ½ reg pin	140,0	5.512	1014,0	39.921	65.0	143	20,5	45.2 (FV) 20,1 44.3 (TL)
H8 HD	8"	QL80 DHD380	4 ½ reg pin	194,0	7.638	1245,0	49.016	200.0	441	46,8	103.2 (FV) 41,6 91.7 (TL)
H8 SL	8"	QL80 DHD380	4 ½ reg pin	184,0	7.244	1245,0	49.016	172.0	379	46,8	103.2 (FV) 41,6 91.7 (TL)
Hyper 101	10"	SD10/N100	6 ¾ reg pin	225,0	8.858	1549,0	61.000	346	763	65	143
Hyper 121	12"	DHD112	6 ¾ reg pin	272,0	10.709	1872,0	73.700	626	1380	112	247
		N120	6 ¾ reg pin	272,0	10.709	1872,0	73.700	626	1380	125	276
		SD12	6 ¾ reg pin	272,0	10.709	1872,0	73.700	626	1380	125	276
		QL120	6 ¾ reg pin	286,0	11.260	1889,0	74.370	763	1682	125	276
Hyper 141	14"	N125	6 ¾ reg pin	320,0	12.598	1945,0	76.700	913	2012	188	414
H18	18"	N180	8 ¾ reg pin	400,0	15.748	1646,0	64.803	1057	2330	347	765 (FV) 300 661 (TL)
Hyper 241	24"	N240	8 ¾ reg pin HEX210	533,0	20.984	2355,0	92.717	2575	5677	595	1312
Hyper 241 TL	24"	N240	8 ¾ reg pin HEX210	533,0	20.984	2331,0	91.772	2640	5820	585	1290
Hyper 331	33"	H331	HEX275	736,6	29.000	2540,0	100	5567	12273	1552	3422

DTH Hammers

Please contact Robit's sales for more options or regarding the



DTH hammers: sales@robitgroup.com



HYPER SERIES HAMMERS

BR2

Hammer 70 mm (2 ¾") - 80 mm (3 ⅝") diameter holes

Valved hammer for high performance at low operating air pressures

- Robust and reliable
- Standard box with pin backheads (alternatives available upon request)
- RD50 and BR2 threads
- Positive fitting check valve to guard against the ingress of ground water debris

Component parts

Ref	Description	Part number
1	Wear Sleeve	HSB2S00
2	Inner Cylinder	HSB2S01
3	Bearing	HSB2S02
4	Piston	HSB2S03
5	Air Metering Plug	IPP04
6	Bevelled Valve Housing	HSB2S04
7	Centraliser	HSB2S05
8	Disc Valve	HSB2S06
9	Valve Chest	HSB2S07
10	Backhead	HSB2S3811F
11	Backhead O-ring	HSB2S14
12	Bit Retaining Ring	HSB2S37ST
13	Backhead Spacer	HSB2S12
14	Chuck	HSB2S35ST
15	Chuck Sealing Ring	HSB2S13
16	Check Valve	IPRCV01
17	Check Valve Spring	IPRCVS01
18	Split Spacer	HSB2S36ST
	Complete Hammer	BR2S01

Air consumption (Pressure at Compressor)

PSI	BAR	m ³ /min	ft ³ /min
100	6.9	0.8	26.7
150	10.3	1.4	49.0
200	13.8	2.1	75.4
250	17.2	3.0	105.4

Hammer specification

	Imperial	Metric
Weight (less bit)	28.6 lbs	13 kg
Length (less bit)	33"	838 mm
Outside dia.	2.44"	64 mm
Piston weight	4 lbs	1.8 kg

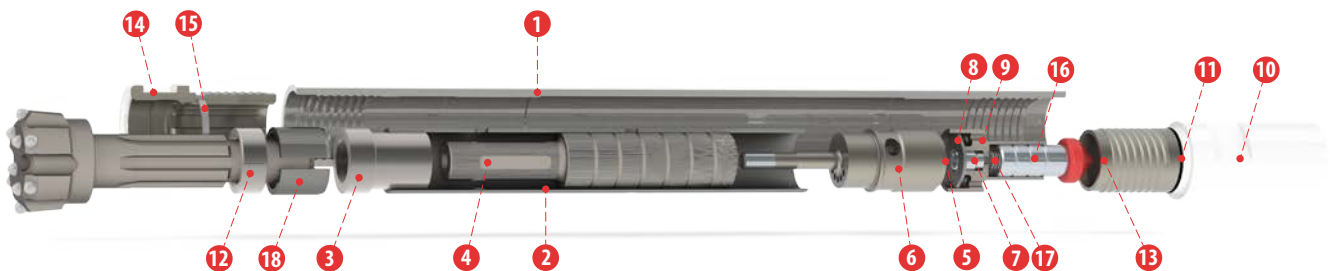
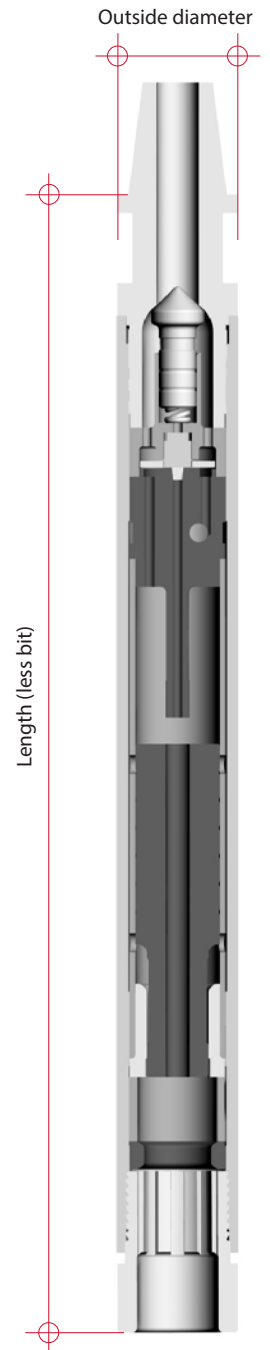

HYPER SERIES HAMMERS

HYPER 31

Hammer 90 mm (3 1/2") - 100 mm (4") diameter holes

Highly dependable hammer with simple but rugged design

- Optimum performance at air pressures ranging from 10 to 24 bar (150-350 psi)
- Standard 2 3/8" API reg. pin backhead
- DHD 3.5 bit shank fitting (alternative Mach33 available upon request)

Component parts

Ref	Description	Part number
1	Backhead	HSH313801M
2	Backhead O-ring	IPBOR01
3	Check valve	IPRCV01
4	Check valve spring	IPRCVS01
5	Compression ring	HSH3128
6	Diverter	HSH3120
7	Piston DHD 3.5	HSH3103040
8	Wear Sleeve	HSH3100
9	Piston retaining ring	HSH3132
10	Bit retaining O-ring	IPBOR01
11	Bit retainer DHD 3.5	HSH3137040
12	Breakout washer	HSH3126
13	Chuck DHD 3.5	HSH3135040
	Service Kit Hyper 31 incl. (2,4,5,10,12)	HSH31SERVKIT
	Repair Kit Hyper 31 incl. (1,2,3,4,5,6,7,8,10)	HSH31REPKITXL3
	Complete Hammer	BR31H40

Air consumption

PSI	BAR	m ³ /min	ft ³ /min
100	6.9	1.4	50.0
150	10.3	2.6	91.9
200	13.8	4.0	141.5
250	17.2	5.6	197.8
300	20.7	7.4	260.0
350	24.2	9.3	327.7

Hammer specification

	Imperial	Metric
Weight (less bit)	49.5 lbs	22.5 kg
Length (less bit)	32.75"	832 mm
Outside dia.	3.12"	79.2 mm
Piston weight	10.78 lbs	4.9 kg

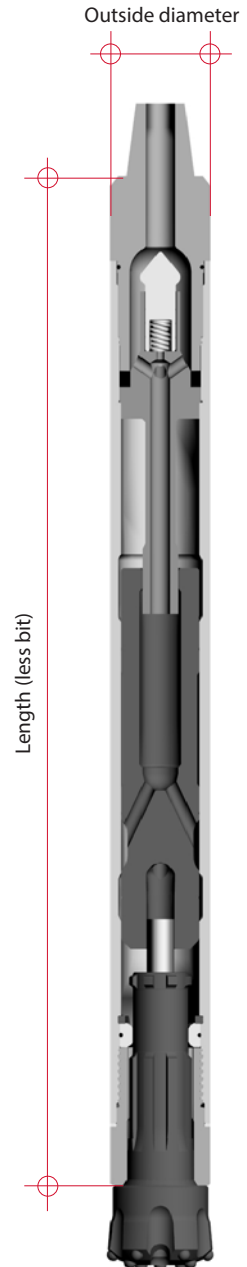

DTH Hammers

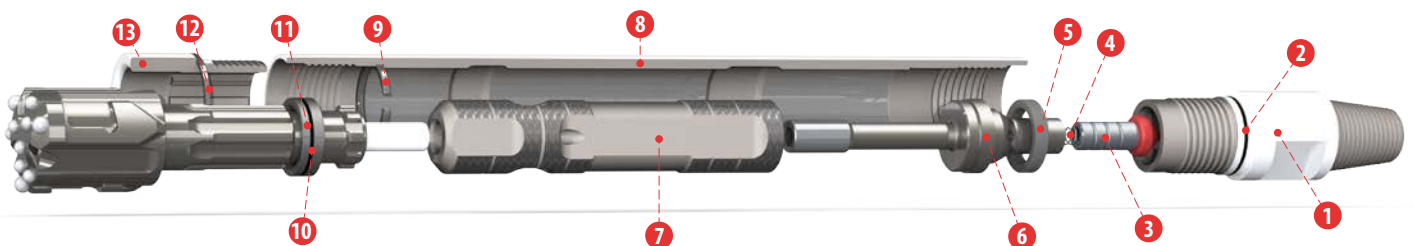

H SERIES HAMMERS



DTH hammer for 108 mm / 4 1/4" (SL) - 140 mm (5 1/2") diameter holes (TD40 or DHD340 fitting)
 115 mm / 4 1/2" (HD)

Complete Hammer

	TD40	HD	FV	MX	2002352	H4 TD40 HD FV MX API 2 3/8IN Reg Pin
			HF	2002813	H4 TD40 HD FV HF API 2 3/8IN Reg Pin	
		TL	MX	2002353	H4 TD40 HD TL MX API 2 3/8IN Reg Pin	
			HF	2002814	H4 TD40 HD TL HF API 2 3/8IN Reg Pin	
		SL	FV	MX	2002967	H4 TD40 SL FV MX API 2 3/8IN Reg Pin
			HF	2002972	H4 TD40 SL FV HF API 2 3/8IN Reg Pin	
	DHD340	HD	FV	MX	2002706	H4 DHD340 HD FV MX API 2 3/8IN Reg Pin
			HF	2003354	H4 DHD340 HD FV HF API 2 3/8IN Reg Pin	
		SL	FV	MX	2002981	H4 DHD340 SL FV MX API 2 3/8IN Reg Pin
			HF	2003342	H4 DHD340 SL FV HF API 2 3/8IN Reg Pin	

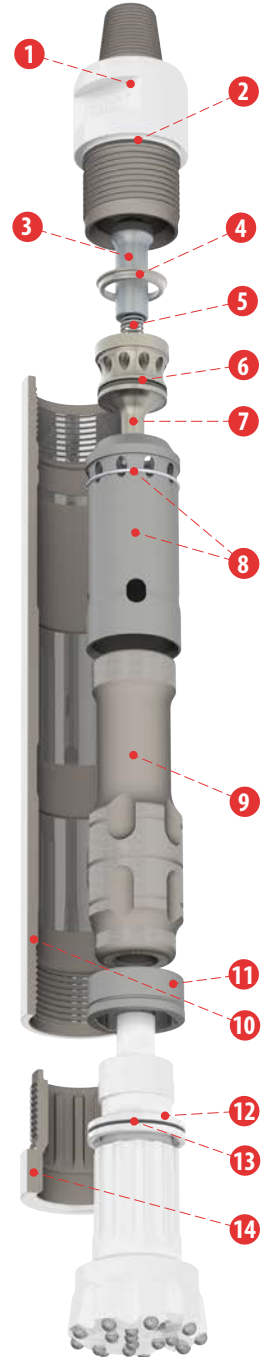

Components

Ref	Description	Part number TD40	Part number DHD340
1	Top adaptor/Backhead HD (SL)	2002340 (2002968)	
2	Backhead O-ring	06M-00-0542	
3	Check valve	2002351	
4	Make up ring	2002341	
5	Check valve spring	06J-25-0544	
6	Air distributor O-ring	06M-00-0541	
7	Air distributor	2002342	
8a	Inner cylinder assembly - MX (Maximum Performance)	2002854	
8b	Inner cylinder assembly - HF (High Efficiency)	2002853	
9	Piston FV, Foot valved (TL, Tubeless)	2002345 (2002346)	2002702
10	Wear sleeve HD (SL)	2002347 (2002969)	
11	Guide bush FV (TL)	2002348 (2002349)	2002698
12	Bit retaining ring assembly (incl. 13, O-ring)	2002350	2002700
13	Bit retaining ring O-ring	06M-00-0543	
14	Chuck HD (SL)	2002518 (2002970)	2002701 (2002978)
	Service kit H4 incl. (2, 5, 6, 13)	2002861	
	Repair kit H4 HD (SL) incl. (2, 3, 4, 5, 6, 12, 14)	2002862 (2003508)	2003355 (2003343)
	Life Kit H4 HD (SL) FV API 2 3/8" Pin incl. (1, 10, 11, 14)	2002825 (2003318)	2003356 (2003344)
	Life Kit H4 HD (SL) TL API 2 3/8" Pin incl. (1, 10, 11, 14)	2002826 (2003509)	-

Air Consumption

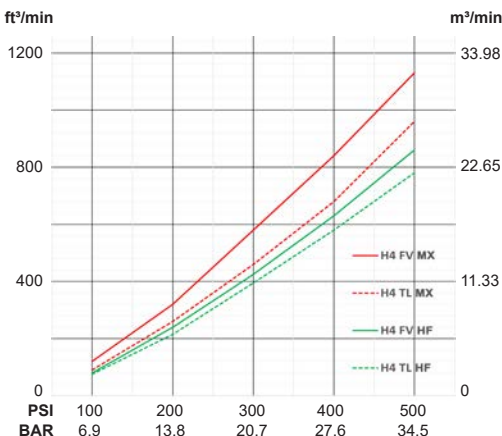

Hammer Specifications

	Imperial	Metric
Weight (HD, less bit)	83.8 lbs	38.0 kg
Weight (SL, less bit)	75.0 lbs	34.0 kg
Length (less bit)	33.86"	860 mm
Outside Dia. (HD)	4.02"	102 mm
Outside Dia. (SL)	3.86"	98 mm
Discard Limit	3.54"	90 mm
Piston Weight (FV)	18.5 lbs	8.4 kg
Piston Weight (TL)	17.9 lbs	8.1 kg

HD = Heavy Duty
 SL = Slim Line
 FV = Foot Valved
 TL = Tubeless
 MX = Maximum Performance
 HF = High Efficiency

Please contact Robit's sales regarding the



DTH hammers: sales@robitgroup.com

H SERIES HAMMERS



DTH hammer for 127 mm / 5" (SL) - 165 mm (6 1/2") diameter holes (QL50 or DHD350 fitting)
140 mm / 5 1/2" (HD)

Complete Hammer

Series	Configuration	Option	Part Number	Description
QL50	HD	FV	1281126	H5 QL50 HD FV MX API 3 1/2IN Reg Pin
		HF	1281128	H5 QL50 HD FV HF API 3 1/2IN Reg Pin
	TL	MX	1281125	H5 QL50 HD TL MX API 3 1/2IN Reg Pin
		HF	1281127	H5 QL50 HD TL HF API 3 1/2IN Reg Pin
	SL	FV	1281305	H5 QL50 SL FV MX API 3 1/2IN Reg Pin
		HF	1281307	H5 QL50 SL FV HF API 3 1/2IN Reg Pin
DHD350	HD	FV	1281304	H5 QL50 SL TL MX API 3 1/2IN Reg Pin
		HF	1281306	H5 QL50 SL TL HF API 3 1/2IN Reg Pin
	SL	FV	1281241	H5 DHD350 HD FV MX API 3 1/2IN Reg Pin
		HF	1281243	H5 DHD350 HD FV HF API 3 1/2IN Reg Pin
	SL	FV	1281379	H5 DHD350 SL FV MX API 3 1/2IN Reg Pin
		HF	1281375	H5 DHD350 SL FV HF API 3 1/2IN Reg Pin

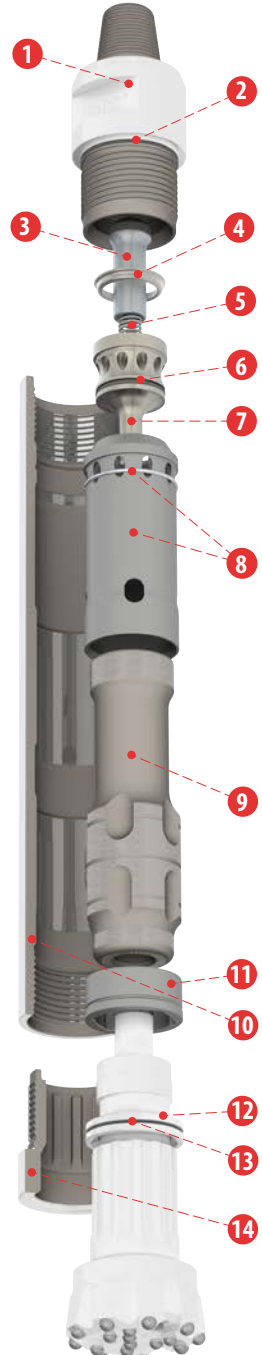

DTH Hammers

Components

Ref	Description	Part number QL50	Part number DHD350
1	Top adaptor/Backhead HD (SL)	1281142 (1281300)	
2	Backhead O-ring	9003608	
3	Check valve	9003556	
4	Make up ring	1281144	
5	Check valve spring	9003555	
6	Air distributor O-ring	9003609	
7	Air distributor	1281143	
8a	Inner cylinder assembly - MX (Maximum Performance)	1281131	
8b	Inner cylinder assembly - HF (High Efficiency)	1281132	
9	Piston FV, Foot valved (TL, Tubeless)	1281139 (1281138)	1281247
10	Wear sleeve HD (SL)	1281133 (1281309)	
11	Guide bush FV (TL)	1281135 (1281134)	1281249
12	Bit retaining ring assembly (incl. 13, O-ring)	1281141	1281251
13	Bit retaining ring O-ring	1098824	
14	Chuck HD (SL)	1281140 (1281301)	1281250 (1281376)
	Service kit H5 incl. (2, 5, 6, 13)	1281281	
	Repair kit H5 HD (SL) incl. (2, 3, 4, 5, 6, 12, 14)	1281282 (1281344)	1281382 (1281381)
	Life Kit H5 HD (SL) FV API 3 1/2" Pin incl. (1, 10, 11, 14)	1281334 (1281345)	1281384 (1281383)
	Life Kit H5 HD (SL) TL API 3 1/2" Pin incl. (1, 10, 11, 14)	1281283 (1281380)	-

Air Consumption

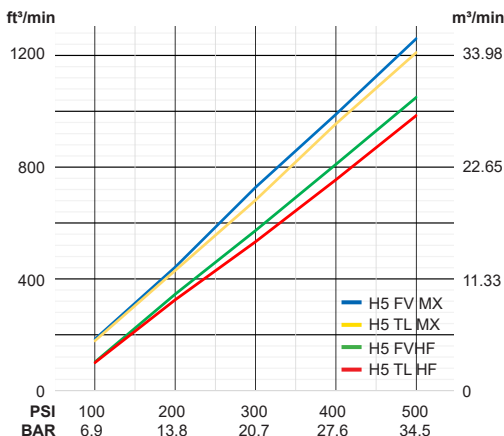

Hammer Specifications

	Imperial	Metric
Weight (HD, less bit)	179.7 lbs	61.5 kg
Weight (SL, less bit)	119.0 lbs	54.0 kg
Length (less bit)	36.02"	915 mm
Outside Dia. (HD)	4.96"	126 mm
Outside Dia. (SL)	4.72"	120 mm
Discard Limit	4.49"	114 mm
Piston Weight (FV)	30.6 lbs	13.9 kg
Piston Weight (TL)	26.0 lbs	11.8 kg

HD = Heavy Duty
SL = Slim Line
FV = Foot Valved
TL = Tubeless
MX = Maximum Performance
HF = High Efficiency

Please contact Robit's sales regarding the



DTH hammers: sales@robitgroup.com

H SERIES HAMMERS

Robit H6

DTH hammer for 152 mm / 6" (SL) - 216 mm / 8 1/2" diameter holes (QL60 or DHD360 fitting)
158 mm / 6 1/4" (HD)

Complete Hammer

Model	Configuration	Part Number	Description
QL60	HD	FV MX 1281089	H6 QL60 HD FV MX API 3 1/2IN Reg Pin
		HF 1281091	H6 QL60 HD FV HF API 3 1/2IN Reg Pin
	SL	FV MX 1281297	H6 QL60 SL FV MX API 3 1/2IN Reg Pin
		HF 1281299	H6 QL60 SL FV HF API 3 1/2IN Reg Pin
	HD	TL MX 1281088	H6 QL60 HD TL MX API 3 1/2IN Reg Pin
		TL HF 1281090	H6 QL60 HD TL HF API 3 1/2IN Reg Pin
DHD360	HD	FV MX 1281392	H6 DHD360 HD FV MX API 3 1/2IN Reg Pin
		HF 1281394	H6 DHD360 HD FV HF API 3 1/2IN Reg Pin
	SL	FV MX 1281391	H6 DHD360 SL FV MX API 3 1/2IN Reg Pin
		HF 1281393	H6 DHD360 SL FV HF API 3 1/2IN Reg Pin

Components

Ref	Description	Part number QL60	Part number DHD360
1	Top adaptor/Backhead HD (SL)	1281077 (1281292)	
2	Backhead O-ring	1098881	
3	Check valve	9003390	
4	Make up ring	1281080	
5	Check valve spring	9003388	
6	Air distributor O-ring	1242029	
7	Air distributor	1281068	
8a	Inner cylinder assembly - MX (Maximum Performance)	1281114	
8b	Inner cylinder assembly - HF (High Efficiency)	1281115	
9	Piston FV, Foot valved (TL, Tubeless)	1281078 (1281074)	1281402
10	Wear sleeve HD (SL)	1281069 (1281308)	
11	Guide bush FV (TL)	1281079 (1281074)	1281403
12	Bit retaining ring assembly (incl. 13, O-ring)	1281073	1281401
13	Bit retaining ring O-ring	1098846	
14	Chuck HD (SL)	1281072 (1281293)	1281400 (1281399)
	Service kit H6 incl. (2, 5, 6, 13)	1281284	
	Repair kit H6 HD (SL) incl. (2, 3, 4, 5, 6, 12, 14)	1281285 (1281342)	1281396 (1281395)
	Life Kit H6 HD (SL) FV API 3 1/2" Pin incl. (1, 10, 11, 14)	1281335 (1281343)	1281398 (1281397)
	Life Kit H6 HD (SL) TL API 3 1/2" Pin incl. (1, 10, 11, 14)	1281286 (1281407)	-

Air Consumption

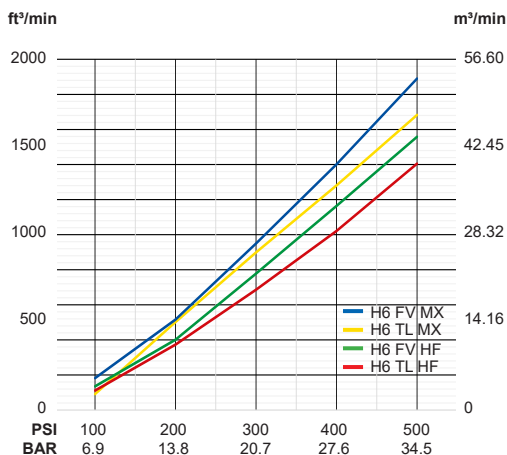

Hammer Specifications

	Imperial	Metric
Weight (HD, less bit)	164.2 lbs	74.5 kg
Weight (SL, less bit)	143.3lbs	65.0 kg
Length (less bit)	39.92"	1014 mm
Outside Dia. (HD)	5.75"	146 mm
Outside Dia. (SL)	5.51"	140 mm
Discard Limit	5.12"	130 mm
Piston Weight (FV)	45.2 lbs	20.5 kg
Piston Weight (TL)	44.3 lbs	20.1 kg

Please contact Robit's sales regarding the

Robit MARATHON

DTH hammers: sales@robitgroup.com

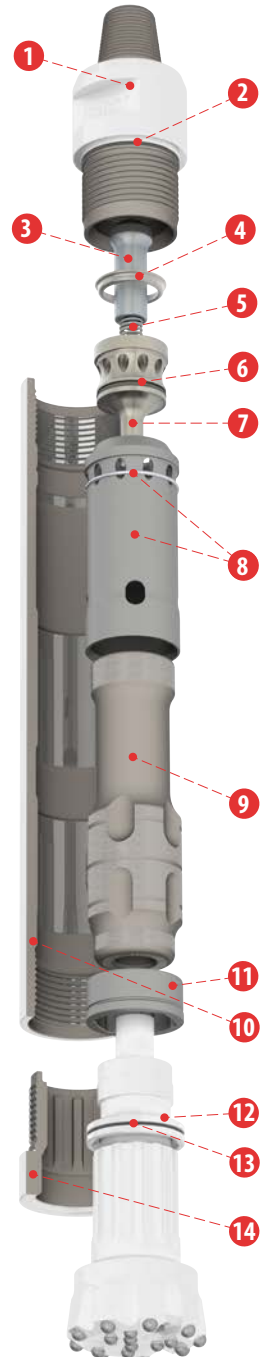

HD = Heavy Duty
SL = Slim Line
FV = Foot Valved
TL = Tubeless
MX = Maximum Performance
HF = High Efficiency

H SERIES HAMMERS



DTH hammer for 203 mm / 8" (SL) - 254 mm (10") diameter holes (QL80 or DHD380 fitting)
 216 mm / 8 1/2" (HD)

Complete Hammer

Series	Model	Configuration	Part Number	Description
QL80	HD	FV MX	1281094	H8 QL80 HD FV MX API 4 1/2IN Reg Pin
		HF	1281096	H8 QL80 HD FV HF API 4 1/2IN Reg Pin
	SL	FV MX	2002987	H8 QL80 SL FV MX API 4 1/2IN Reg Pin
		HF	2002988	H8 QL80 SL FV HF API 4 1/2IN Reg Pin
	HD	TL MX	1281093	H8 QL80 HD TL MX API 4 1/2IN Reg Pin
		TL HF	1281095	H8 QL80 HD TL HF API 4 1/2IN Reg Pin
DHD380	HD	FV MX	1281387	H8 DHD380 HD FV MX API 4 1/2IN Reg Pin
		HF	1281388	H8 DHD380 HD FV HF API 4 1/2IN Reg Pin
	SL	FV MX	1281390	H8 DHD380 SL FV MX API 4 1/2IN Reg Pin
		HF	1281389	H8 DHD380 SL FV HF API 4 1/2IN Reg Pin

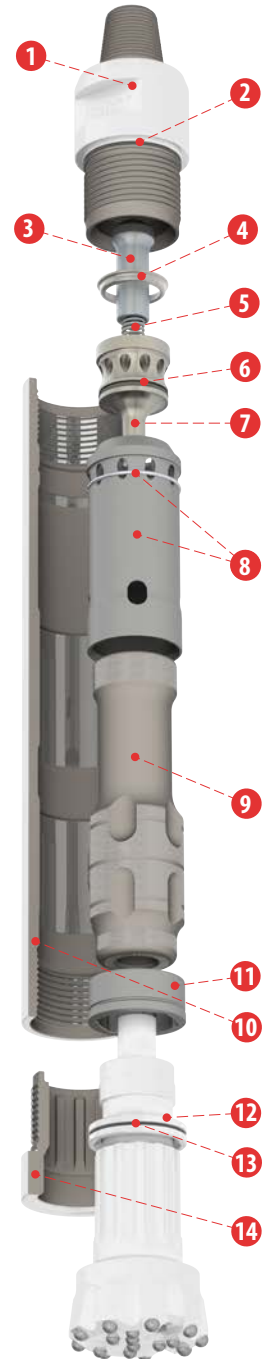

DTH Hammers

Components

Ref	Description	Part number QL80	Part number DHD380
1	Top adaptor/Backhead HD (SL)	1281108 (2002982)	
2	Backhead O-ring	9003540	
3	Check valve	9003436	
4	Make up ring	1281110	
5	Check valve spring	9003435	
6	Air distributor O-ring	9003542	
7	Air distributor	1281109	
8a	Inner cylinder assembly - MX (Maximum Performance)	1281116	
8b	Inner cylinder assembly - HF (High Efficiency)	1281117	
9	Piston FV, Foot valved (TL, Tubeless)	1281103 (1281102)	1281371
10	Wear sleeve HD (SL)	1281099 (2002983)	
11	Guide bush FV (TL)	1281101 (1281100)	1281372
12	Bit retaining ring assembly (incl. 13, O-ring)	1281107	1281369
13	Bit retaining ring O-ring	1119422	
14	Chuck HD (SL)	1281106 (2002986)	1281370 (1281373)
	Service kit H8 incl. (2, 5, 6, 13)	1281287	
	Repair kit H8 HD (SL) incl. (2, 3, 4, 5, 6, 12, 14)	1281288 (1281340)	1281408 (1281412)
	Life Kit H8 HD (SL) FV API 3 1/2" Pin incl. (1, 10, 11, 14)	1281336 (1281341)	1281410 (1281411)
	Life Kit H8 HD (SL) TL API 3 1/2" Pin incl. (1, 10, 11, 14)	1281289 (1281406)	-

Air consumption

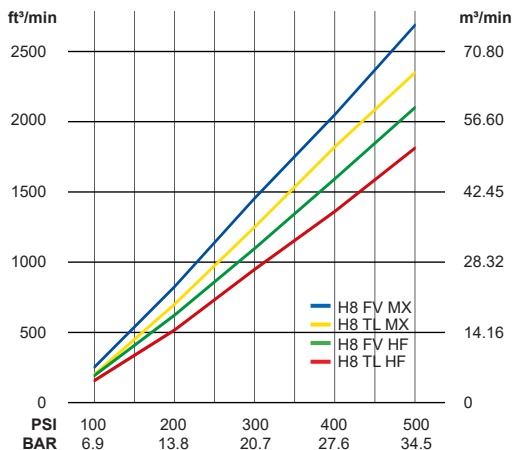

Hammer Specifications

	Imperial	Metric
Weight (HD, less bit)	441.0 lbs	200.0 kg
Weight (SL, less bit)	379.2 lbs	172.0 kg
Length (less bit)	49.02"	1245 mm
Outside Dia. (HD)	7.64"	194 mm
Outside Dia. (SL)	7.24"	184 mm
Discard Limit	6.85"	174 mm
Piston Weight (FV)	103.2 lbs	46.8 kg
Piston Weight (TL)	91.7 lbs	41.6 kg

HD = Heavy Duty
 SL = Slim Line
 FV = Foot Valved
 TL = Tubeless
 MX = Maximum Performance
 HF = High Efficiency

Please contact Robit's sales regarding the



DTH hammers: sales@robitgroup.com

HYPER SERIES HAMMERS

HYPER 101

Hammer 254 mm (10") - 305 mm (12") diameter holes

A reliable hammer designed to perform over a wide range of operating air pressures

- Fitted with a positive seating water check valve and a solid choke
- Standard 6 5/8" API reg. pin backhead
- SD10 bit shank fitting (alternative N100 available upon request)

Component parts

Ref	Description	Part number
1	Backhead	HSH1013880M
2	Check valve	HSH12108
3	Check valve spring	HSH12110
4	Diverter	HSH10120
5	Compression buffer	HSH10128
6	Control tube holder	HSH10131
7	Control tube buffers (2)	HSH10129
8	Control tube	HSH10130
9	Piston SD10	HSH10103046
10	Wear Sleeve	HSH10100
11	Piston retaining ring	HSH10132
12	Bit retaining ring SD10	HSH10137046
13	Bit retaining ring O-ring	HSH10137A046
14	Chuck SD10	HSH10135046
15	Breakout washer	HSH10126
	Service Kit Hyper 101 incl.(3,5,7,13,15)	HSH101SERVKIT
	Repair Kit Hyper 101 incl.(2,3,5,7,11,12,13,14,15)	HSH101REPKIT
	Complete Hammer	BR101H01

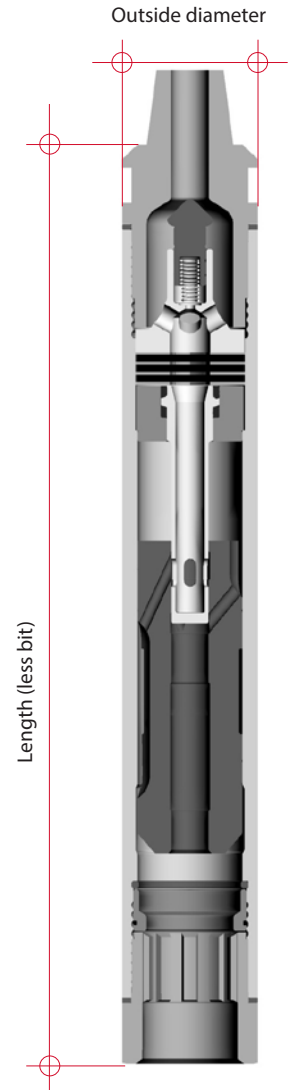

Air consumption (Pressure at Compressor)

PSI	BAR	m ³ /min	ft ³ /min
100	6.9	13	455
150	10.3	22	792
200	13.8	33	1149
250	17.2	43	1522
300	20.7	54	1900

Hammer specification

	Imperial	Metric
Weight (less bit)	763 lbs	346 kg
Length (less bit)	61"	1549 mm
Outside dia.	8.86"	225 mm
Piston weight	143 lbs	65 kg

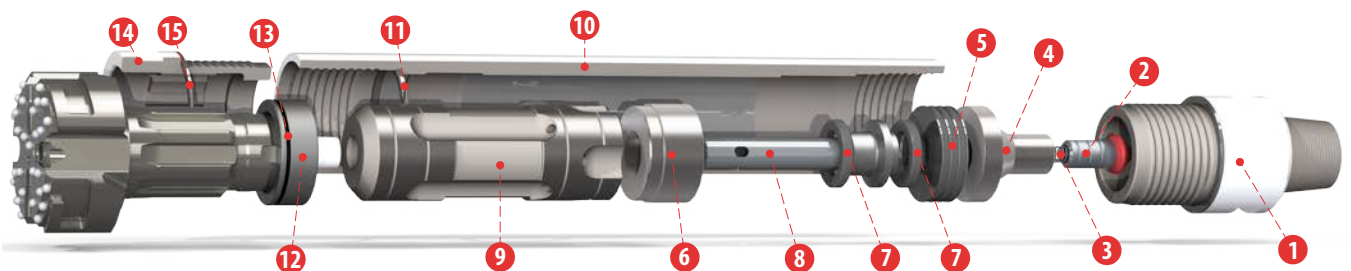

HYPER SERIES HAMMERS

HYPER 121

Hammer 302 mm (11 7/8") - 445 mm (17 1/2") diameter holes

A reliable hammer designed to perform over a wide range of operating air pressures

- Fitted with a positive seating water check valve and a solid choke
- Standard 6 5/8" API reg. pin backhead
- SD12 bit shank fitting (alternative QL120 and DHD112 available upon request)

Component parts

Ref	Description	Part number
1	Backhead	HSH1213880M
2	Backhead / Chuck O-ring (2)	HSH12114
3	Check Valve	HSH12108
4	Check Valve Spring	HSH12110
5	Diverter	HSH12120
6	Compression Buffer	HSH12128
7	Control Tube Holder	HSH12131
8	Control Tube Buffers (2)	HSH12129
9	Control Tube O-ring	HSH12130A
10	Control Tube	HSH12130
11	Piston SD12/DHD112	HSH12103048
12	Wear Sleeve	HSH12100
13	Piston Retaining Ring	HSH12132
15	Bit Retainer (pair) SD12	HSH12137048
16	Bit Retainer O-ring	HSH12137A050
17	Chuck SD12	HSH12135048
19	Breakout washer backhead	HSH12126
20	Breakout Washer chuck	HSH12125
	Service Kit Hyper 121 incl. (2,4,6,8,9,16,19,20)	HSH121SERVKIT
	Repair Kit Hyper 121 incl.(2,3,4,6,8,9,13,15,16,17,19,20)	HSH121REPKIT
	Complete Hammer	BR121H03

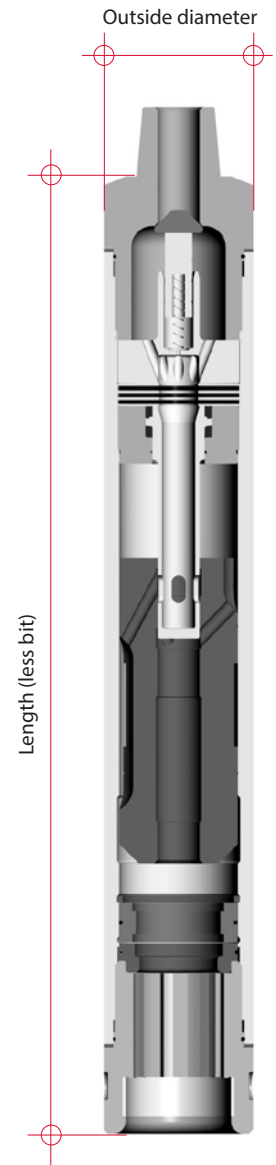

DTH Hammers

Air consumption (Pressure at Compressor)

PSI	BAR	m ³ /min	ft ³ /min
100	6.9	20	718
150	10.3	35	1242
200	13.8	51	1804
250	17.2	67	2382

Hammer specification

	Imperial	Metric
Weight (less bit)	1380 lbs	626 kg
Length (less bit)	73.7"	1872 mm
Outside dia.	10.7"	272 mm
Piston weight	275 lbs	125 kg

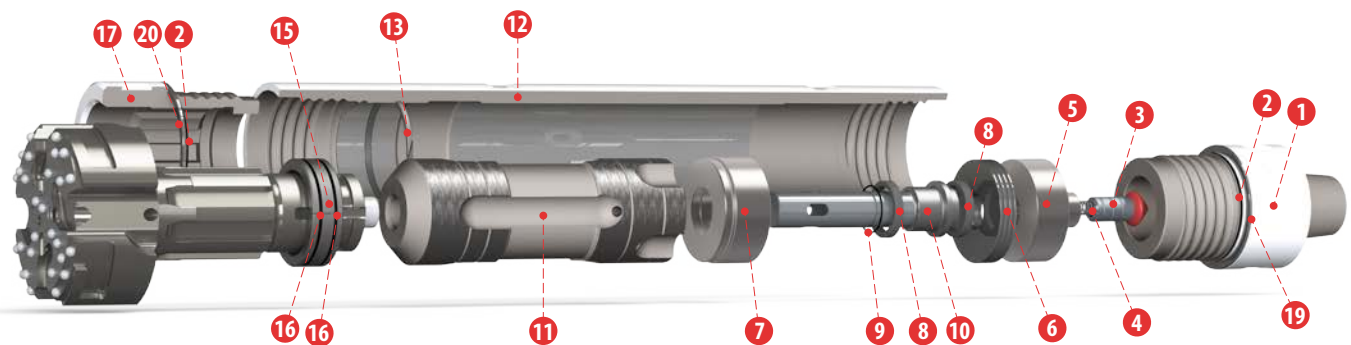

HYPER SERIES HAMMERS

HYPER 141

Hammer 350 mm (13 3/4") - 508 mm (20") diameter holes

A valveless hammer designed to perform over a wide range of operating air pressures

- Fitted with a positive seating water check valve and a solid choke
- Standard 6 5/8" API reg. pin backhead
- N125 bit shank fitting (alternative considered upon request)

Component parts

Ref	Description	Part number
1	Backhead	HSH1413880M
2	Check Valve	HSH12108
3	Check Valve Spring	HSH12110
4	Diverter	HSH14120
5	Compression Buffer	HSH14128
6	Control Tube Holder	HSH14131
7	Control Tube Buffers (2)	HSH14129
8	Control Tube	HSH14130
9	Control Tube O-ring	HSH14130A
10	Piston	HSH14103125
11	Wear Sleeve	HSH14100
12	Bit Retainer (pair)	HSH14137125
13	Bit Retainer O-ring	HSH12137A050
14	Chuck (N125 C/W drive plate slot)	HSH14135125
15	Chuck Bearing	HSH14135125BE
16	Breakout Washer (chuck)	HSH14126
17	Breakout Washer (Backhead)	HSH14126
18	Backhead O-ring	HSH14114
	Service Kit Hyper 141 incl. (5,7,9,13,16,18)	HSH141SERVKIT
	Repair Kit Hyper 141 incl. (2,3,5,7,9,12,13,14,15,16,18)	HSH141REPKIT
	Complete Hammer	BR141H01

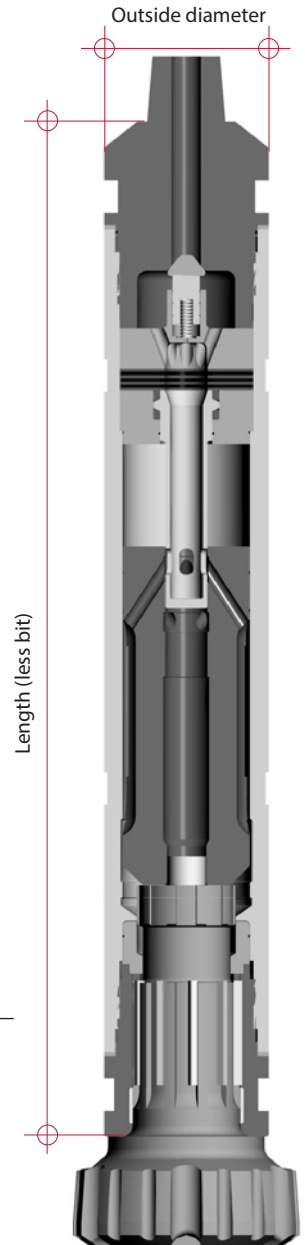

Air consumption (Pressure at Compressor)

PSI	BAR	m ³ /min	ft ³ /min
100	6.9	24	834
150	10.3	41	1464
200	13.8	61	2137
250	17.2	80	2839

Hammer specification

	Imperial	Metric
Weight (less bit)	2412 lbs	913 kg
Length (less bit)	76.6"	1945 mm
Outside dia.	12.6"	320 mm
Piston weight	414 lbs	188 kg

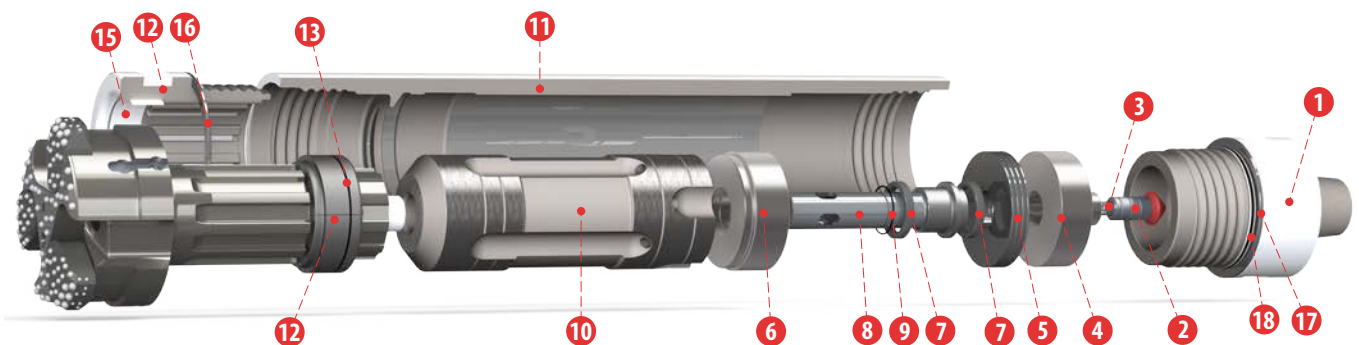

H SERIES HAMMERS



DTH hammer for 458 mm (18") - 711 mm (28") diameter holes with N180 fitting

Component parts

Ref	Description	Part number FV	Part number TL
1	H18 BACKHEAD 8 5-8IN REG PIN	4000375	
2	H18 BREAKOUT WASHER	9004111	
3	H18 BREAKOUTWASHER SAFETY BUFFER	4000405	
4	HYPER 181 B/HEAD "O" RING	HSH18114	
5	H18 CHECK VALVE	4000380	
6	H18 CHECK VALVE SPRING (S423)	9004109	
7	H18 COMPRESSION RING	9004110	
8	H18 VALVE CHEST	4000378	
9	H18 SWITCH SPACER	4000383	
10	H18 CONTROL TUBE	4000379	
11	H18 TUBE HOLDER	4000381	
12	H18 WEARSLEEVE	4000377	
13	H18 PISTON N180 FV/TL	4000376	4000386
14	H18 RETAINING SNAP RING	9004112	
15	H18 GUIDE BUSH FV/TL	4000382	4000387
16	H18 GUIDE BUSH O RING FV/TL	9004113	9004114
17	H18 BIT RETAINER N180	4000404	
18	H18 Chuck N180	4000390	
19	HYPER181 CHUCK BEARING - N180	HSH18135180BE	
	DTH HAMMER H18 FV MX 8 5-8 API REG PIN	4000384	
	DTH HAMMER H18 FV HF 8 5-8 API REG PIN	4000374	
	DTH HAMMER H18 TL MX 8 5-8 API REG PIN		4000385
	DTH HAMMER H18 TL HF 8 5-8 API REG PIN		4000388

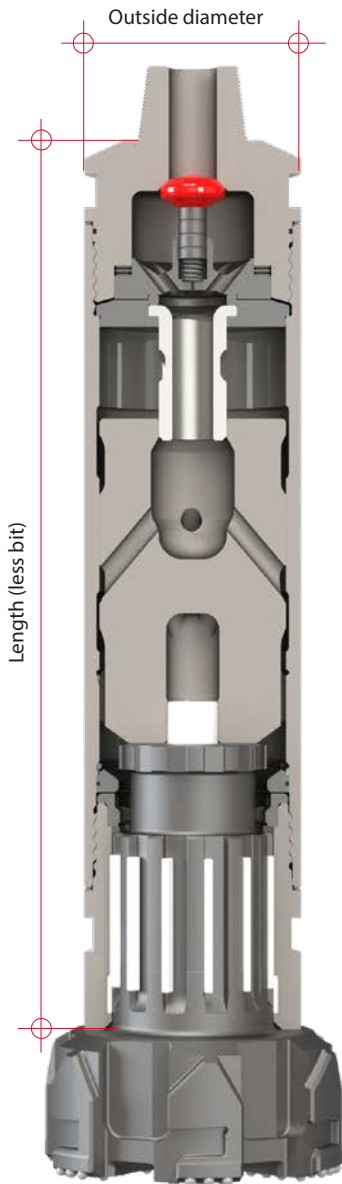

DTH Hammers

Air consumption, H18 (Pressure at Compressor)

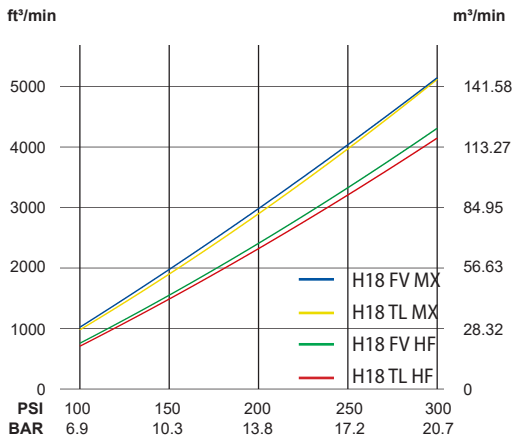

Hammer specification

	Imperial	Metric
Weight (less bit)	2330 lbs	1057 kg
Length (less bit)	64.8"	1646 mm
Outside dia.	15.7"	400 mm
Piston weight (FV)	765 lbs	347 kg
Piston weight (TL)	661 lbs	300 kg
FV = Foot Valved		
TL = Tubeless		
MX = Maximum Performance		
HF = High Efficiency		

Robit® H18 hammer offers Maximum Performance or High Efficiency version by changing parts order.

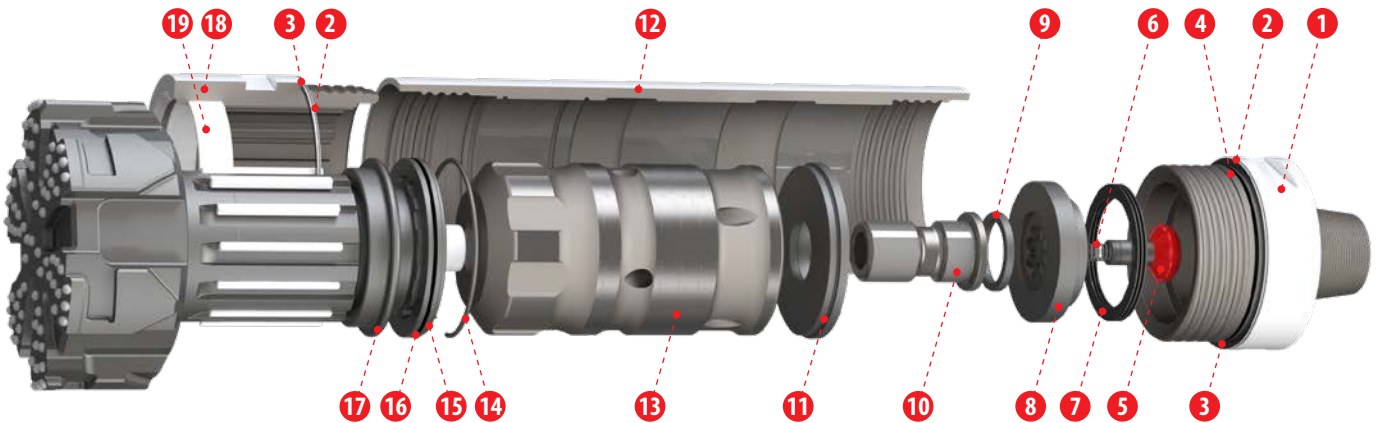

HYPER SERIES HAMMERS

HYPER 241

Hammer 610 mm (24") - 864 mm (34") diameter holes

A valveless hammer that excels at moderate operating air pressures

- Optimum performance at air pressures ranging from 7 to 15.5 bar (100-225 psi)
- Standard 8 5/8" API reg. pin backhead (an 8 5/8" API reg box backhead can be supplied)
- Fitted with a positive seating check valve
- N240 bit shank fitting

Component parts

Ref	Description	Part number
1	Backhead Adaptor 8 5/8" reg Pin	HSH2413682M
2	Backhead Adaptor Breakout Washer	HSH24127
3	Backhead	HSH24138
4	Check Valve	HSH18108
5	Check Valve Spring	HSH24110
6	Valve Chest	HSH24104
7	Compression Buffer	HSH24128
8	Backhead O-ring	HSH24114
9	Internal Backhead O-ring	HSH24114A
10	Tube Buffers (2)	HSH24129
11	Control Tube	HSH24130
12	Piston	HSH24103240
13	Bit Retaining Ring	HSH24137240
14	Bit Retainer O-ring (2)	HSH24137A240
15	Chuck	HSH24135240
16	Chuck Bearing	HSH24135240BE
17	Breakout Washer Backhead & Chuck	HSH24125
18	Internal Washer Adaptor	HSH24106
19	Wear Sleeve	HSH24100
	Service Kit Hyper 241 incl. (2,5,7,8,9,10,14,17)	HSH241SERVKIT
	Repair Kit Hyper 241 incl. (2,4,5,7,8,9,10,13,14,16,17)	HSH241REPKIT
	Complete Hammer	BR241H01

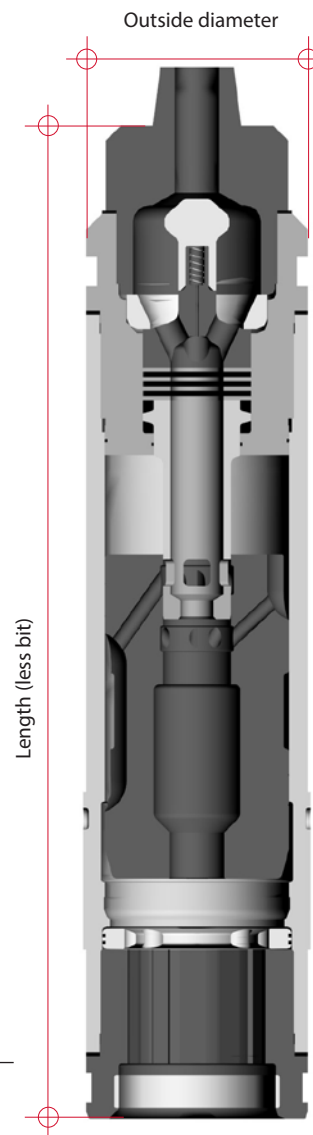

Air consumption (Pressure at Compressor)

PSI	BAR	m ³ /min	ft ³ /min
100	6.9	80	2823
150	10.3	136	4790
200	13.8	194	6859
250	17.2	254	8966

Hammer specification

	Imperial	Metric
Weight (less bit)	5676 lbs	2575 kg
Length (less bit)	91.9"	2334 mm
Outside dia.	21"	533 mm
Piston weight	1312 lbs	595 kg

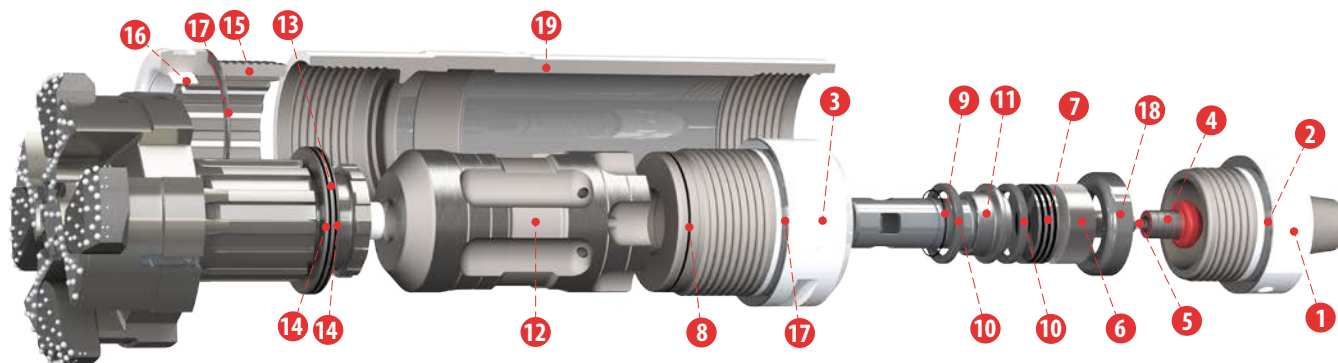

HYPER SERIES HAMMERS

HYPER 241 TL

Hammer 610 mm (24") - 864 mm (34") diameter holes

A tubeless hammer designed for horizontal drilling with a wide operating air pressure range

- Operating air pressure range from 6.9 to 24 bar (100-350 psi)
- Standard 8 5/8" API reg. pin backhead (alternative connections available upon request)
- N240 bit shank fitting (the footvalve of the bit must be removed before fitting)

Component parts

Ref	Description	Part number
1	Backhead Adapter 8 5/8" Reg Pin	HSH2413682M
2	Backhead Adapter Breakout Washer	HSH24127
3	Check Valve	HSH18108
4	Check Valve Spring	HSH24110
5	Internal Washer Adapter	HSH24106
6	Valve Chest	HSH24104
7	Compression Buffer	HSH24128
8	Tube Buffers (2)	HSH24129
9	Control Tube	4000121
10	Backhead	HSH24138
11	Internal Backhead O-ring	HSH24114A
12	Backhead O-ring	HSH24114
13	Breakout Washer Backhead and Chuck	HSH24125
14	Piston	4000122
15	Wear Sleeve	4000119
16	Bit Retainer O-ring (2)	HSH24137A240
17	Bit Retainer	HSH24137240
18	Bearing O-ring (2)	9001743
19	Bearing	HSH24102HZ
20	Chuck	HSH24135240
21	Chuck Bearing	HSH24135240BE
	Complete Hammer	BR241H01HZ

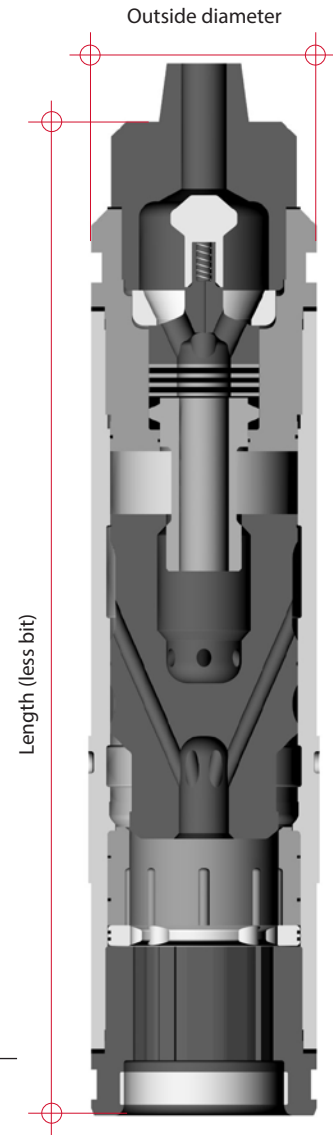

DTH Hammers

Air consumption (Pressure at Compressor)

PSI	BAR	m ³ /min	ft ³ /min
100	6.9	72	2525
150	10.3	131	4638
200	13.8	202	7141
250	17.2	283	9980
300	20.7	372	13119
350	24.1	468	16532

Hammer specification

	Imperial	Metric
Weight (less bit)	5820 lbs	2640 kg
Length (less bit)	91.78"	2331 mm
Outside dia.	21"	533 mm
Piston weight	1290 lbs	585 kg

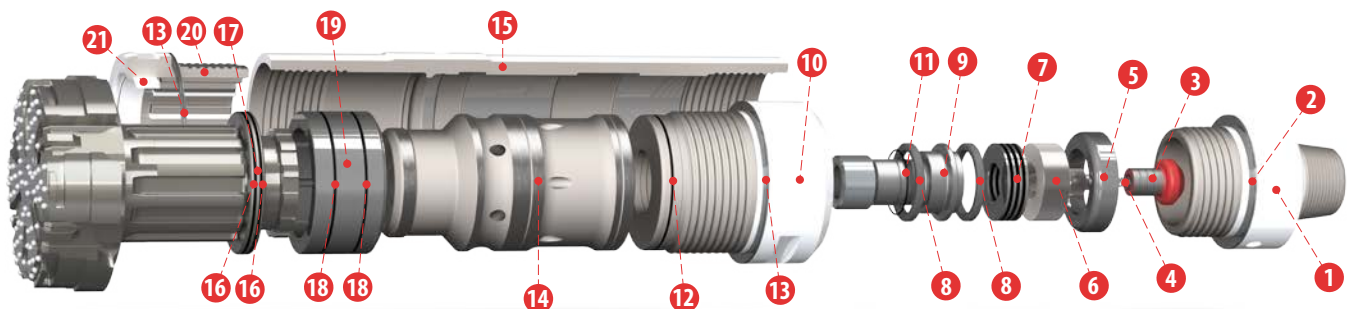

HYPER SERIES HAMMERS

HYPER 331

Hammer 838 mm (33") - 1320 mm (52") diameter holes (other sizes available upon request)

A reliable hammer designed to perform over a wide range of operating air pressures

- HEX275 pin backhead (alternative connections available upon request)
- Designed to transfer maximum energy to the button bit
- Supplied with a highly durable shank as standard

Component parts

Ref	Description	Part number
1	Backhead adaptor	HSH3313683M
2	Breakout washer	HSH33127
3	Compression buffer	HSH33128
4	Check valve	HSH18108
5	Check valve spring	HSH18110
6	Diverter	HSH33120
7	Control tube	HSH33130
8	Backhead	HSH33138
9	Backhead internal O-ring	HSH33114A
10	Backhead breakout washer	HSH33126
11	Piston	HSH33103
12	Wear Sleeve	HSH33100
13	Bit bearing O-ring (2)	HSH33186A
14	Bit bearing	HSH33186
15	Bit retainer O-ring (2)	HSH33137A
16	Bit retainer	HSH33137
17	Chuck breakout washer	HSH33126
18	Chuck	HSH33135
19	Chuck bearing	HSH33135BE
	Service Kit Hyper 331 incl. (3,4,10,15)	HSH331SERVKIT
	Repair Kit Hyper331 incl. (3,4,5,10,15,16,18)	HSH331REPKIT
	Complete Hammer	4000217

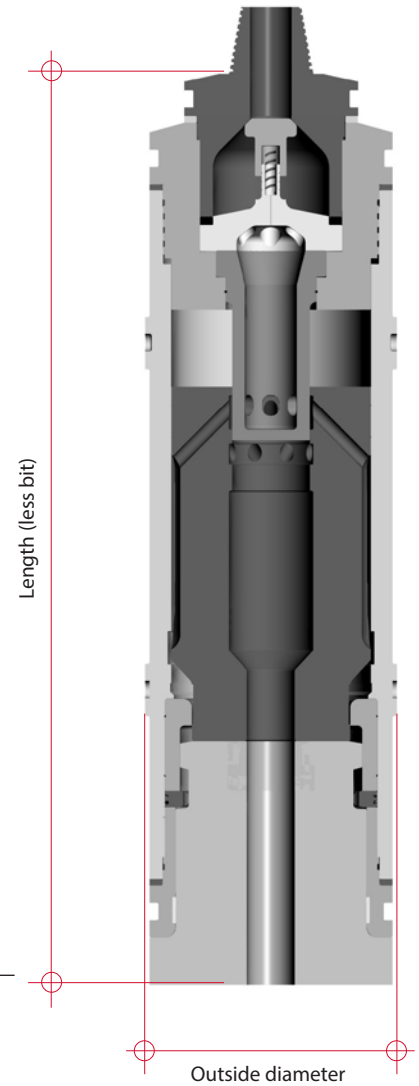

Air consumption

PSI	BAR	m ³ /min	ft ³ /min
100	6.9	102	3589
150	10.3	179	6330
200	13.8	262	9262
250	17.2	349	12316

Hammer specification

	Imperial	Metric
Weight (less bit)	12273 lbs	5567 Kg
Length (less bit)	100"	2540 mm
Outside dia.	29.0"	736.6 mm
Piston weight	3414 lbs	1552 Kg
Button Bit type	H331	

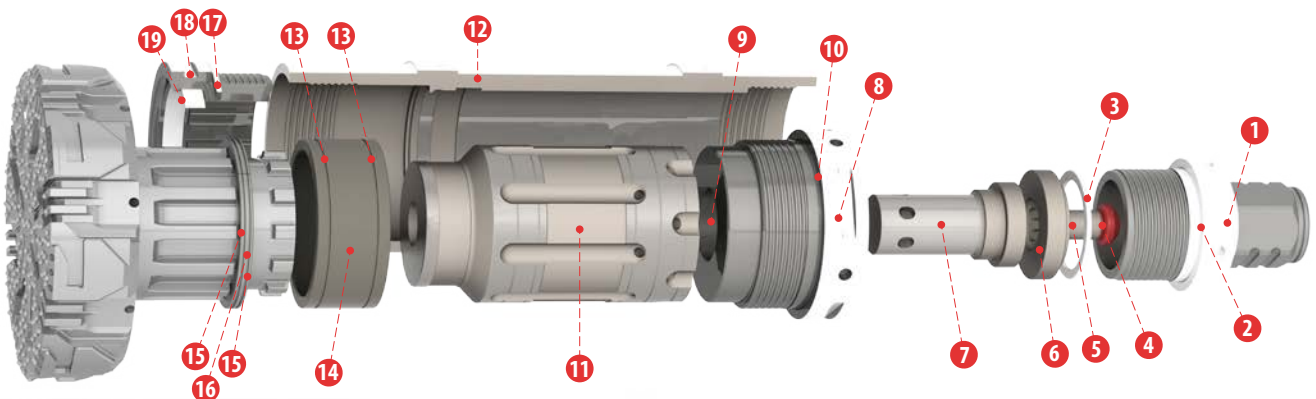



SHOCK ABSORBERS

2" - 33"

Order code	DTH Hammer	Top connector	Bottom connector	Outside diameter		Length		Weight
				[mm]	[in]	[mm]	[in]	[kg]
Shock Absorber 2"	2"	2 3/8" reg pin	2 3/8" reg box	62,0	2.44	346	13.62	7,5
Shock Absorber 3"	3"	2 3/8" reg pin	2 3/8" reg box	79,4	3.13	457	17.99	14,3
Shock Absorber 4"	4"	2 3/8" reg pin	2 3/8" reg box	95,4	3.76	483	19.02	22,1
Shock Absorber 5"	5"	3 1/2" reg pin	3 1/2" reg box	115,0	4.53	514	20.24	33,2
Shock Absorber 6"	6"	3 1/2" reg pin	3 1/2" reg box	140,0	5.51	578	22.76	53,0
Shock Absorber 8"	8"	4 1/2" reg pin	4 1/2" reg box	178,0	7.01	591	23.27	84,0
Shock Absorber 10"	10"	6 5/8" reg pin	6 5/8" reg box	216,0	8.50	635	25.00	98,0
Shock Absorber 12"	12" - 14"	6 5/8" reg pin	6 5/8" reg box	254,0	10.00	724	28.50	229,0
Shock Absorber 18"	18"	8 5/8" reg pin	8 5/8" reg box	400,0	15.75	700	27.56	579,0
Shock Absorber 30"	24" - 30"	10" Beco male	10" Beco female	508,0	20.00	950	37.40	1256,0
Shock Absorber 33"	33"	275 Hex male	275 Hex female	711,0	28.00	1055	41.54	2725,0



Shock Absorbers

2"- 6" Shock Absorbers

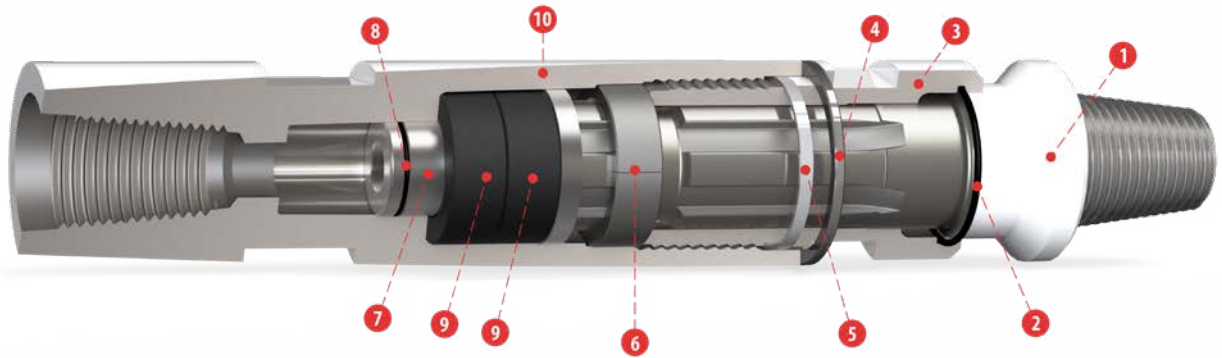

Size	HDSA2	HDSA3	HDSA4	HDSA5	HDSA6
Effective length	346 mm / 13.62"	457 mm / 17.93"	483 mm / 19.02"	514 mm / 20.27"	578 mm / 22.76"
Outside diameter	62 mm / 2.44"	79.4 mm / 3.13"	95.4 mm / 3.76"	115 mm / 4.53"	140 mm / 5.51"
Net weight	7,5 kg / 16.5 lbs	14,3 kg / 31.5 lbs	22,1 kg / 48.7 lbs	33,2 kg / 73.2 lbs	53,0 kg / 116.8 lbs

Ref	Description	Part number				
		HDSA2	HDSA3	HDSA4	HDSA5	HDSA6
1	Top connector	SA02HD0811F (RD50 Box)	SA03HD0801M (2 3/8" reg. pin)	SA04HD0801M (2 3/8" reg. pin)	SA05HD0803M (3 1/2" reg. pin)	SA06HD0803M (3 1/2" reg. pin)
2	Seal O-ring*	N / A	SA03HD03	SA04HD03	SA05HD03	SA06HD03 (2 of)*
3	Splined Nut	HSB2S35ST	SA03HD01	SA04HD01	SA05HD01	SA06HD01
4	Breakout washer	N / A	SA03HD25	SA04HD25	SA05HD25	SA06HD25
5	Splined Nut Seal	HSB2S13	SA03HD10	SA04HD10	SA05HD10	SA06HD10
6	Retainer ring	HSB2S37ST	SA03HD011	SA04HD011	SA05HD011	SA06HD011
7	Thrust guide	SA02HD12	SA03HD12	SA04HD12	SA05HD12	SA06HD12
8	Thrust guide O-ring	SA02HD12A	SA03HD12A	SA04HD12A	SA05HD12A	SA06HD12A
9	Buffer	SA02HD05	SA03HD05	SA04HD05	SA05HD05	SA06HD05
10	Bottom connector	SA02HD0911M (RD50 Pin)	SA03HD0901F (2 3/8" reg. box)	SA04HD0901F (2 3/8" reg. box)	SA05HD0903F (3 1/2" reg. box)	SA06HD0903F (3 1/2" reg. box)
	Complete Shock Absorber	SA02HD11MF	SA03HD01MF	SA04HD01MF	SA05HD03MF	SA06HD03MF

8"-10" Shock Absorbers

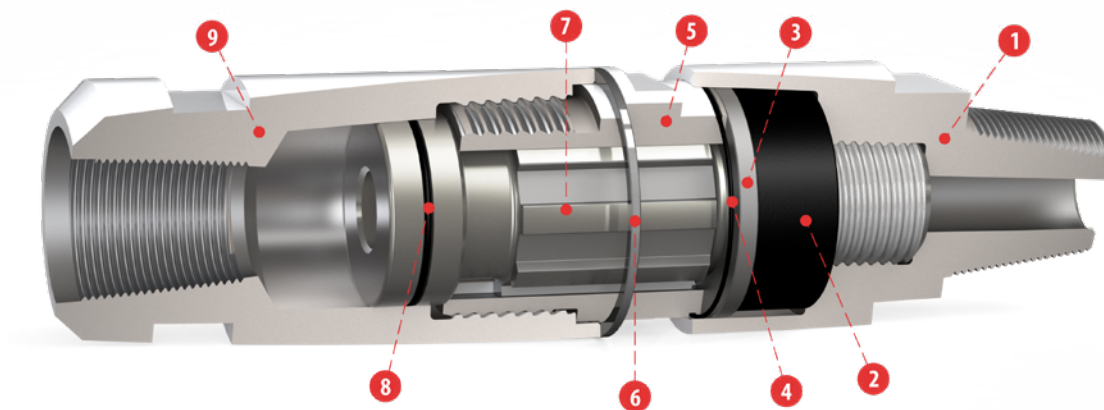

Size	HDSA8 (4 1/2 reg. pin)	HDSA10 (6 5/8 reg. pin)
Effective length	591 mm / 23.2"	635 mm / 25.00"
Outside diameter	178 mm / 7.01"	216 mm / 8.50"
Net weight	84 kg / 185.2 lbs	98 kg / 216.1 lbs

Ref	Description	Part number	
		HDSA8	HDSA10
1	Top connector	SA08ST0804M (4 1/2" reg. pin)	SA10ST0880M (6 5/8" reg. pin)
2	Buffer	SA08ST05	SA10ST05
3	Thrust Washer	SA08ST04	SA10ST04
4	Nut O-ring	SA08ST10	SA08ST10
5	Nut	SA08ST01	SA10ST01
6	Breakout Washer	SA08ST25	SA10ST25
7	Shaft	SA08ST02	SA10ST02
8	Shaft O-ring	SA08ST03	SA10ST03
9	Bottom Connector	SA08ST0904F (4 1/2" reg. box)	SA10ST0980F (6 5/8" reg. box)
	Complete Shock Absorber	SA08ST04MF	SA10ST80MF

12"-14" Shock Absorbers

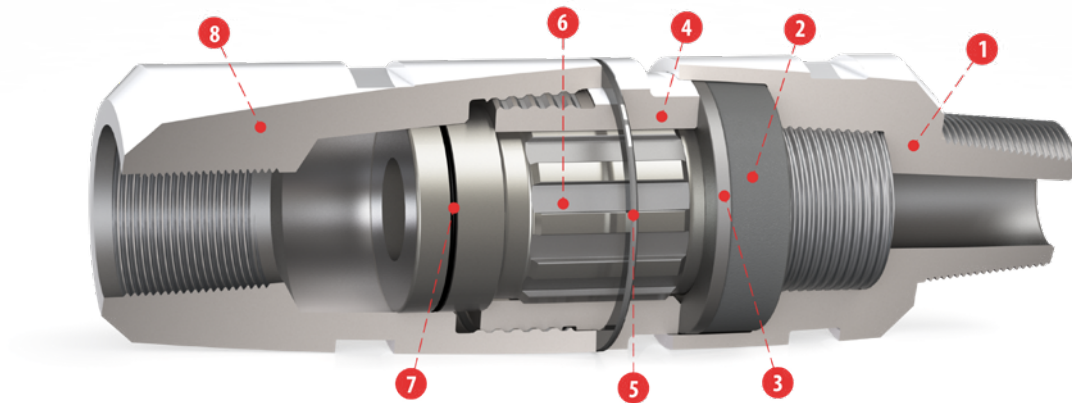

Size	HDSA12	HDSA18
Effective length	724 mm / 28.50"	711 mm / 28.00"
Outside diameter	254 mm / 10.00"	406 mm / 16.00"
Net weight	229 kg / 504 lbs	598 kg / 1316 lbs

Ref	Description	Part number	
		HDSA12	HDSA18
1	Top Connector	SA12ST0880M (6 5/8" API Reg Pin)	SA18ST0882M (8 5/8" API Reg Pin)
2	Buffer	SA12ST05	SA18ST05
3	Thrust Washer	SA12ST04	SA18ST04
4	Nut	SA12ST01	SA18ST01
5	Breakout Washer	SA12ST25	SA18ST25
6	Shaft	SA12ST02	SA18ST02
7	Shaft O-ring	SA12ST03	SA18ST03
8	Bottom Connector 6 5/8" API Reg Box	SA12ST0980F	SA18ST0982F
	Complete Shock Absorber	SA12ST80MF	SA18ST82MF

18" Shock Absorber

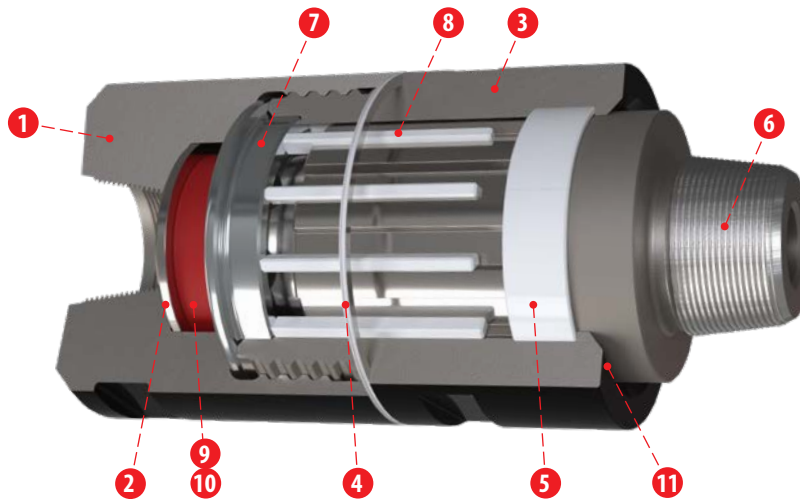

Size	SA18
Effective length	700 mm / 27.56"
Outside diameter	400 mm / 15.75"
Net weight	579 kg / 1276.5 lbs

Ref	Description	Part number
		SA18
1	Bottom connector Api 8 5/8"	2003595
2	SA18 Buffer plate	2003594
3	H18 Chuck N180	4000390
4	H18 Breakout washer	9004111
5	Chuck bearing - N180	HSH18135180BE
6	SA18 Shaft Api 8 5/8" Pin	2003596
7	H18 Bit retainer N180	4000404
8	N180 Drive plate	DP180
9	12" S/A Buffer	SA12ST05
10	8" S/A Buffer	SA08ST05
11	SA18 V-Seal (optional)	2003716
Complete Shock Absorber		4000421

24"-33" Shock Absorbers

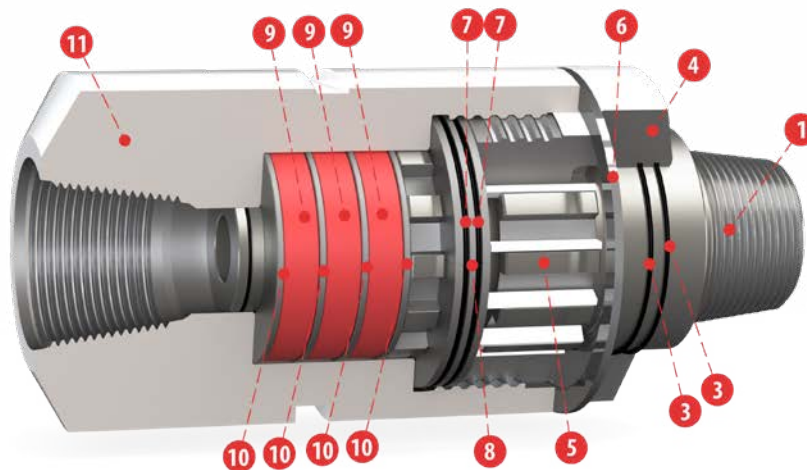

Size	HDSA30	HDSA33
Effective length	950 mm / 37.42"	1055 mm / 41.54"
Outside diameter	508 mm / 20.00"	711 mm / 28.00"
Net weight	1250 kg / 2755.8 lbs	2725 kg / 6008.0 lbs

Ref	Description	Part number	
		HDSA30	HDSA33
1	Top Connector	4000051 (10" Beco Pin)	SA33HD08275HEXM (275 Hex Male)
2	Shaft O-ring	9000425	9003194
3	Nut O-ring x 2	9000426	9003193
4	Nut	4000052	SA33HD01
5	12off Drive Plates	9000467	SA33HDDP
6	Breakout Washer	SA30HD25	SA33HD25
7	Retainer O-ring x 2	9000427	-
8	Split Retaining Ring	SA30HD11	-
9	Rubber Buffers x 3	9000469	SA33HD05 (Buffer Pack)
10	Steel Plates x 4	9000428	SA33HD05 (Buffer Pack)
11	Bottom Connector	4000059 (10" Beco Box)	SA33HD9275HEXF (275 Hex Female)
	Complete Shock Absorber	SA30HD83MF	SA33HD275HEXMF



DRILL PIPES

76 mm - 323 mm Single pipe

406 mm - 1220 mm Double pipe



Drill Pipes

Drill Pipes - Single Pipe

Order code	Diameter D		Wall thickness T		Tool joint	Length L		*Weight						
	[mm]	[in]	[mm]	[in]		[mm]	[in]	[kg*]						
Drill pipe 76	76	2.992	4	0.157	2 3/8" reg.	1000	39.370	12						
						1500	59.055	16						
						2000	78.740	19						
						3000	118.110	26						
						6000	236.220	47						
				6,3	0.248	2 3/8" reg.	1000	39.370	15					
							1500	59.055	21					
							2000	78.740	26					
							3000	118.110	36					
							6000	236.220	68					
Drill pipe 89	89	3.504	4	0.157	2 3/8" reg.	1000	39.370	16						
						1500	59.055	21						
						2000	78.740	25						
						3000	118.110	33						
						6000	236.220	58						
				6,3	0.248	2 3/8" reg.	1000	39.370	19					
							1500	59.055	26					
							2000	78.740	32					
							3000	118.110	42					
							6000	236.220	83					
Drill pipe 102	102	4.016	6,3	0.248	2 7/8" reg.	1000	39.370	25						
						1500	59.055	33						
						2000	78.740	40						
						3000	118.110	55						
						6000	236.220	100						
Drill pipe 114	114	4.488	6,3	0.248	3 1/2" reg./ or 3" Beco	1000	39.370	29						
						1500	59.055	38						
						2000	78.740	46						
						3000	118.110	63						
						6000	236.220	114						
Drill pipe 139	139	5.472	8,8	0.346	3 1/2" reg./ or 3 1/2" Beco	1000	39.370	45						
						1500	59.055	59						
						2000	78.740	76						
						3000	118.110	104						
						6000	236.220	187						
						12000	472.441	370						
						Drill pipe 168	168	6.614	12,5	0.492	4 1/2" reg./ or 4" Beco	1000	39.370	120
												1500	59.055	145
												2000	78.740	170
												3000	118.110	228
6000	236.220	396												
						12000	472.441	605						
						Drill pipe 193	193	7.598	12,5	0.492	4 1/2" reg./ or 5 1/4" Beco	1000	39.370	126
												1500	59.055	154
												2000	78.740	181
												3000	118.110	236
6000	236.220	410												
						12000	472.441	745						

Order code	Diameter D		Wall thickness T		Tool joint	Length L		*Weight [kg*]
	[mm]	[in]	[mm]	[in]		[mm]	[in]	
Drill pipe 219	219	8.622	12,5	0.492	4 1/2" reg./ or 6" Beco	1000	39.370	159
			(also	20,0 and 25,0)		1500	59.055	191
			2000			78.740	222	
			3000			118.110	285	
			6000			236.220	475	
			12000			472.441	857	
Drill pipe 254	254	10.000	12,5	0.492	6 5/8" reg.	1000	39.370	222
			(also	20,0 and 25,0)		1500	59.055	259
			2000			78.740	296	
			3000			118.110	370	
			6000			236.220	594	
			12000			472.441	1041	
			HEX150	1000	39.370	204		
			1500	59.055	241			
			2000	78.740	279			
			3000	118.110	354			
			6000	236.220	577			
			12000	472.441	1024			
Drill pipe 273	273	10.748	16	0.630	6 5/8" reg./ or 8" Beco	1000	39.370	248
			1500	1500		59.055	299	
				2000		78.740	349	
				3000		118.110	451	
				6000		236.220	755	
				12000		472.441	1363	
			HEX150	1000	39.370	282		
			1500	59.055	333			
			2000	78.740	383			
			3000	118.110	484			
			6000	236.220	788			
			12000	472.441	1396			
Drill pipe 323	323	12.717	16	0.630	6 5/8" reg.	1000	39.370	320
			1500	1500		59.055	381	
				2000		78.740	442	
				3000		118.110	563	
				6000		236.220	927	
				12000		472.441	1654	
			HEX190	1000	39.370	360		
			1500	59.055	421			
			2000	78.740	482			
			3000	118.110	603			
			6000	236.220	966			
			12000	472.441	1693			

Ø 76 - 323 mm

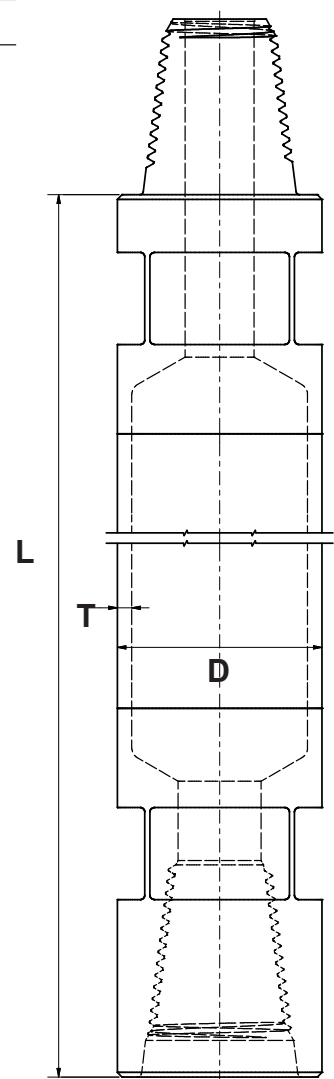

Drill Pipes

*Weight can vary because of pipe joint details.

Drill Pipes - Double Pipe

Order code	Diameter		Wall thickness		Diameter 2		Wall thickness 2		Tool joint	Length		*Weight [kg*]																		
	[mm]	[in]	[mm]	[in]	[mm]	[in]	[mm]	[in]		[mm]	[in]																			
Drill pipe 406	406	15.984	12,5	0.492	273	10.748	16	0.630	8 5/8" reg.	1000	39.370	387																		
										1500	59.055	487																		
										2000	78.740	598																		
										3000	118.110	821																		
										6000	236.220	1507																		
										12000	472.441	2860																		
									HEX190	1000	39.370	414																		
										1500	59.055	525																		
										2000	78.740	637																		
										3000	118.110	859																		
										6000	236.220	1545																		
										12000	472.441	2898																		
										Drill pipe 457	457	17.992	12,5	0.492	273	10.748	16	0.630	8 5/8" reg.	1000	39.370	401								
																				1500	59.055	521								
2000	78.740	640																												
3000	118.110	878																												
6000	236.220	1621																												
12000	472.441	3079																												
HEX190	1000	39.370	440																											
	1500	59.055	559																											
	2000	78.740	678																											
	3000	118.110	917																											
	6000	236.220	1660																											
	12000	472.441	3118																											
	Drill pipe 508	508	20.000	12,5	0.492	273	10.748	16	0.630										HEX190	1000	39.370	467								
																				1500	59.055	594								
2000										78.740	721																			
3000										118.110	975																			
6000										236.220	1777																			
12000										472.441	3341																			
Drill pipe 559										559	22.008	12,5	0.492	323,9	12.752	16	0.630	HEX190	1000	39.370	611									
																			1500	59.055	756									
																			2000	78.740	901									
																			3000	118.110	1191									
																			6000	236.220	2105									
																			12000	472.441	3890									
																		Drill pipe 610	610	24.016	12,5	0.492	323,9	12.752	16	0.630	HEX190	1000	39.370	641
																												1500	59.055	794
	2000	78.740	947																											
	3000	118.110	1252																											
	6000	236.220	2228																											
	12000	472.441	4120																											
	Drill pipe 711	711	27.992	12,5	0.492	323,9	12.752	16	0.630																		HEX190	1000	39.370	704
																												1500	59.055	872
2000										78.740	1040																			
3000										118.110	1377																			
6000										236.220	2478																			
12000										472.441	4589																			
Drill pipe 762										762	30.000	12,5	0.492	323,9	12.752	16	0.630										HEX190	1000	39.370	737
																												1500	59.055	913
																		2000	78.740	1090										
																		3000	118.110	1442										
																		6000	236.220	2608										
																		12000	472.441	4831										

Order code	Diameter		Wall thickness		Diameter 2		Wall thickness 2		Tool joint	Length		*Weight
	[mm]	[in]	[mm]	[in]	[mm]	[in]	[mm]	[in]		[mm]	[in]	[kg*]
Drill pipe 813	813	32.008	12,5	0.492	323,9	12.752	16	0.630	HEX210	1000	39.370	772
										1500	59.055	956
										2000	78.740	1140
										3000	118.110	1508
										6000	236.220	2740
Drill pipe 914	914	35.984	12,5	0.492	323,9	12.752	16	0.630	HEX210	1000	39.370	845
										1500	59.055	1044
										2000	78.740	1244
										3000	118.110	1643
										6000	236.220	3011
Drill pipe 1016	1016	40.000	12,5	0.492	323,9	12.752	16	0.630	HEX210	1000	39.370	923
										1500	59.055	1139
										2000	78.740	1354
										3000	118.110	1785
										6000	236.220	3294
Drill pipe 1220	1220	48.031	12,5	0.492	323,9	12.752	16	0.630	HEX210	1000	39.370	1094
										1500	59.055	1343
										2000	78.740	1590
										3000	118.110	2083
										6000	236.220	3891
										12000	472.441	7179

Ø 406 - 1220 mm

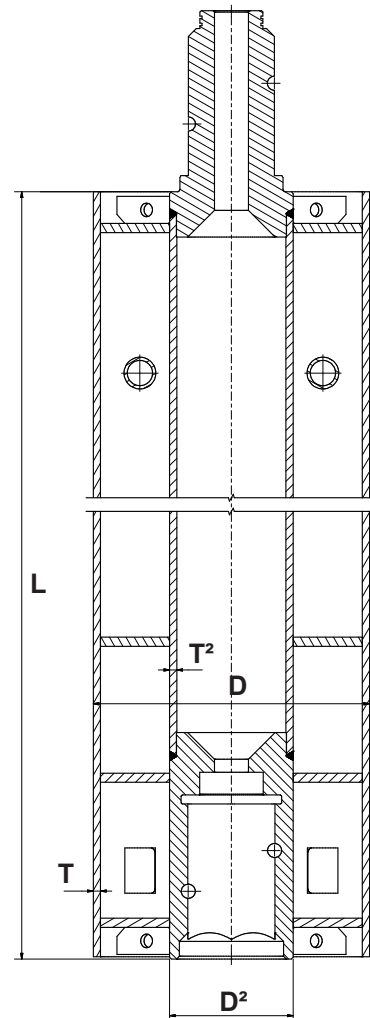

Drill Pipes



ACCESSORIES

Subs

Check valves

Adapters

Hammer sleeves

Air hoses & chain keys

Hammer oil



Accessories

Order code	Diameter		Top connector	Bottom connector	Length		Weight
	[mm]	[in]			[mm]	[in]	
Sub 76,1 - 2 3/8 REG box & pin L140	76,1	3	2 3/8 REG box	2 3/8 REG pin	140	5.512	4
Sub 88,9 - 2 3/8 REG box & pin L140	88,9	3 1/2	2 3/8 REG box	2 3/8 REG pin	140	5.512	5
Sub 88,9 - 2 3/8 REG box & pin L225	88,9	3 1/2	2 3/8 REG box	2 3/8 REG pin	225	8.858	9
Sub 88,9 - 2 3/8 REG box & pin L305	88,9	3 1/2	2 3/8 REG box	2 3/8 REG pin	305	12.008	12
Adapter 114,3 - 2 3/8-3 1/2 REG box & pin L120	114,3	4 1/2	2 3/8 REG box	3 1/2 REG pin	120	4.724	10
Adapter 88,9 - 2 7/8-2 3/8 REG box & pin L134	88,9	3 1/2	2 7/8 REG box	2 3/8 REG pin	134	5.276	5
Adapter 114,3 - 2 7/8-3 1/2 REG box & pin L145	114,3	4 1/2	2 7/8 REG box	3 1/2 REG pin	145	5.709	8
Sub 114,3 - 3 1/2 REG box & pin L250	114,3	4 1/2	3 1/2 REG box	3 1/2 REG pin	250	9.843	16
Adapter 114,3/88,9 - 3 1/2-2 3/8 REG box & pin L300	114,3/88,9	4 1/2 / 3 1/2	3 1/2 REG box	2 3/8 REG pin	300	11.811	17
Adapter 114,3 - 3 1/2-2 3/8 REG box & pin L160	114,3	4 1/2	3 1/2 REG box	2 3/8 REG pin	160	6.299	9
Adapter 140 - 3 1/2-2 1/2 REG box & pin L104	140	5 1/2	3 1/2 REG box	4 1/2 REG pin	104	4.094	13
Adapter 140/114,3 - 4 1/2-3 1/2 REG box & pin L220	140/114,3	5 1/2 / 4 1/2	4 1/2 REG box	3 1/2 REG pin	220	8.661	16
Sub 140 - 4 1/2 REG box & pin L180	140	5 1/2	4 1/2 REG box	4 1/2 REG pin	180	7.087	18
Adapter 196,8/140 - 4 1/2-6 5/8 REG box & pin L215	196,8/140	7 3/4 / 5 1/2	4 1/2 REG box	6 5/8 REG pin	215	8.465	30
Adapter 196,8/114,3 - 6 5/8-3 1/2 REG box & pin L265	196,8/114,3	7 3/4 / 4 1/2	6 5/8 REG box	3 1/2 REG pin	265	10.433	28
Adapter 196,8/140 - 6 5/8-4 1/2 REG box & pin L240	196,8/140	7 3/4 / 5 1/2	6 5/8 REG box	4 1/2 REG pin	240	9.449	31
Adapter 254 - 6 5/8-150 REG box & Hex pin L300	254	10	6 5/8 REG box	Hex 150 pin	300	11.811	120
Adapter 254 - 150-6 5/8 Hex box & REG pin L350	254	10	Hex 150 box	6 5/8 REG pin	350	13.780	148
Adapter 273 - 6 5/8-190 REG box & Hex pin L300	273	10 3/4	6 5/8 REG box	Hex 190 pin	300	11.811	207
Adapter 273 - 190-6 5/8 Hex box & REG pin L550	273	10 3/4	Hex 190 box	6 5/8 REG pin	550	21.654	188
Adapter 273 - 8 5/8-190 REG box & Hex pin L300	273	10 3/4	8 5/8 REG box	Hex 190 pin	300	11.811	208
Adapter 273 - 190-8 5/8 Hex box & REG pin L550	273	10 3/4	Hex 190 box	8 5/8 REG pin	550	21.654	189
Adapter 323 - 6 5/8-210 REG box & Hex pin L300	323	10 3/4	6 5/8 REG box	Hex 210 pin	300	11.811	322
Adapter 323 - 210-6 5/8 Hex box & REG pin L550	323	10 3/4	Hex 210 box	6 5/8 REG pin	550	21.654	296

Order code	Diameter		Top connector	Bottom connector	Length		Weight
	[mm]	[in]			[mm]	[in]	
Check valve 76,1 - 2 3/8 REG box & pin L140	76,1	3	2 3/8 REG box	2 3/8 REG pin	140	5.512	6
Check valve 88,9 - 2 3/8 REG box & pin L140	88,9	3 1/2	2 3/8 REG box	2 3/8 REG pin	140	5.512	7
Check valve 114,3 - 3 1/2 REG box & pin L210	114,3	4 1/2	3 1/2 REG box	3 1/2 REG pin	210	8.268	16
Check valve 127 - 3 1/2 REG box & pin L210	127	5	3 1/2 REG box	3 1/2 REG pin	210	8.268	19
Check valve 140 - 4 1/2-3 1/2 REG box & pin L230	140	5 1/2	4 1/2 REG box	3 1/2 REG pin	230	9.055	24

Hammer sleeves for request. Please contact Robit® sales, tel. +358 3 3140 3400 or sales@robitgroup.com

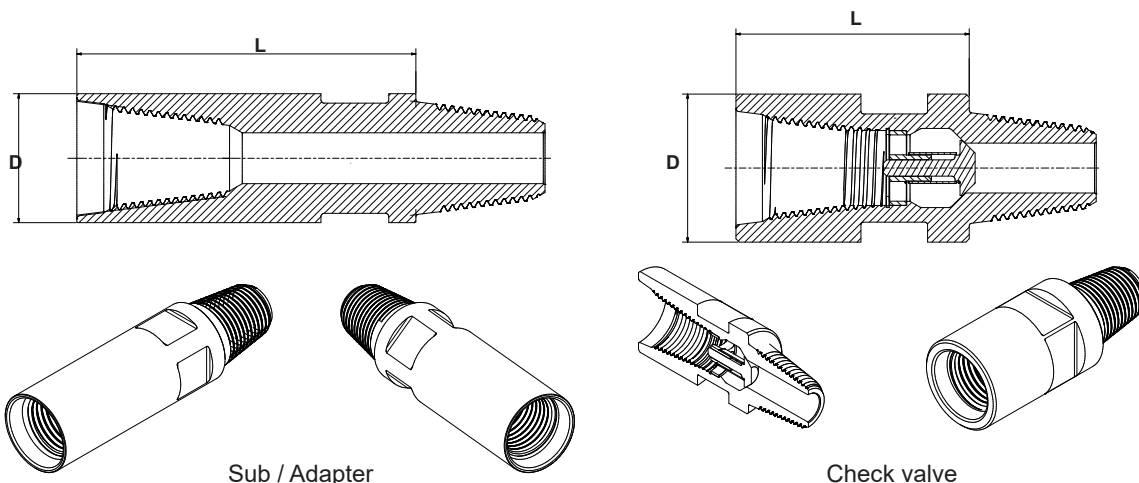

Air hoses & chain keys

35 bar air hoses, lengths 20 m, 35 m and 40 m
Hose covers



Chain key 3-5" & 3-8"
Chain 3-5" DA2344-C12 & 3-8" DA4174-C12
Key body 3-5" DA2344-C12 & 3-8" DA4174-C12



Hammer oil



Usage

Robit AC Bio RockDrill oil has been specifically designed for drilling operations in all rock and soil conditions. It fulfills the OECD 301F requirements for bio oils and it is available in two solutions of different strengths.

Features

Robit AC Bio RockDrill oil has excellent lubrication properties, granting optimally low friction and wear rates.

The oil combines a renewable bio base with a unique mix of additives and enhancers, offering superior protection against corrosion and great features for any conditions.

The oil retains its flow and can be pumped even in cold environments, guaranteeing solid lubrication. Can be poured in temperatures as low as -35°C.

Safety

The oil is free of toxins, will not irritate skin or eyes.

The product has very high boiling and flash points.

Robit AC Bio RockDrill oil is an excellent fit for drilling applications where the lubricant may bleed into the environment.

Robit

The Experts in Drilling Tools

ROBIT PLC

Vikkiniityntie 9

FI-33880 LEMPÄÄLÄ (TAMPERE)

FINLAND

Tel: +358 3 3140 3400

E-mail: sales@robitgroup.com

<https://www.robitgroup.com>

Your distributor:



Robit reserves all rights to any changes in the products and the specifications without prior notice.
Printed: January 2026
Copyright © 2026 by Robit Plc

