

Robit 18

Down the Hole Hammer with N180 fitting

- ✓ **Up to 25% greater power output**
- ✓ **Up to 25% lower air consumption**
- ✓ **Unbeatable for all conditions**



Robit
FURTHER. FASTER.

tel. +358 3 3140 3400 • sales@robitgroup.com • www.robitgroup.com

Follow Robit Plc on our social media channels:



DTH hammer for 458 mm (18") - 711 mm (28") diameter holes with N180 fitting

Component parts

Ref	Description	Part number FV	Part number TL
1	H18 BACKHEAD 8 5-8IN REG PIN		4000375
2	H18 BREAKOUT WASHER		9004111
3	H18 BREAKOUTWASHER SAFETY BUFFER		4000405
4	HYPER 181 B/HEAD "O" RING		HSH18114
5	H18 CHECK VALVE		4000380
6	H18 CHECK VALVE SPRING (S423)		9004109
7	H18 COMPRESSION RING		9004110
8	H18 VALVE CHEST		4000378
9	H18 SWITCH SPACER		4000383
10	H18 CONTROL TUBE		4000379
11	H18 TUBE HOLDER		4000381
12	H18 WEARSLEEVE		4000377
13	H18 PISTON N180 FV/TL	4000376	4000386
14	H18 RETAINING SNAP RING		9004112
15	H18 GUIDE BUSH FV/TL	4000382	4000387
16	H18 GUIDE BUSH O RING FV/TL	9004113	9004114
17	H18 BIT RETAINER N180		4000404
18	H18 Chuck N180		4000390
19	HYPER181 CHUCK BEARING - N180		HSH18135180BE
DTH HAMMER H18 FV MX 8 5-8 API REG PIN		4000384	
DTH HAMMER H18 FV HF 8 5-8 API REG PIN		4000374	
DTH HAMMER H18 TL MX 8 5-8 API REG PIN			4000385
DTH HAMMER H18 TL HF 8 5-8 API REG PIN			4000388

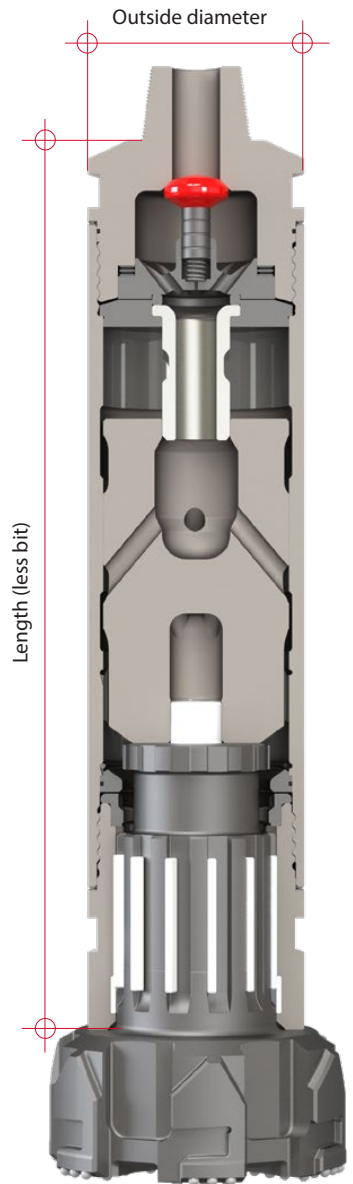

Air consumption, H18 (Pressure at Compressor)

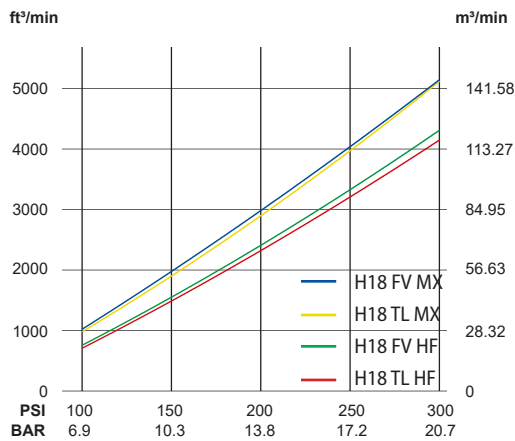

Hammer specification

	Imperial	Metric
Weight (less bit)	2330 lbs	1057 kg
Length (less bit)	64.8"	1646 mm
Outside dia.	15.7"	400 mm
Piston weight (FV)	765 lbs	347 kg
Piston weight (TL)	661 lbs	300 kg

FV = Foot Valved
 TL = Tubeless
 MX = Maximum Performance
 HF = High Efficiency

Robit® H18 hammer offers Maximum Performance or High Efficiency version by changing parts order.

